

INSTRUCTION BOOK

CONDENSATE MANAGEMENT

OSC 12, OSC 25, OSC 50, OSC 85, OSC 170, OSC 300, OSC 625, OSC 1250,
OSC 2500

Atlas Copco



Atlas Copco

Condensate management

OSC 12, OSC 25, OSC 50, OSC 85, OSC 170, OSC 300,
OSC 625, OSC 1250, OSC 2500

Instruction book

Original instructions

COPYRIGHT NOTICE

Any unauthorized use or copying of the contents or any part thereof is prohibited.

This applies in particular to trademarks, model denominations, part numbers and drawings.

This instruction book is valid for CE as well as non-CE labelled machines. It meets the requirements for instructions specified by the applicable European directives as identified in the Declaration of Conformity.

2020 - 09

No. 2920 7196 90

www.atlascopco.com





Table of contents

| | | |
|----------|--|-----------|
| 1 | Safety precautions..... | 3 |
| 1.1 | SAFETY ICONS..... | 3 |
| 1.2 | GENERAL SAFETY PRECAUTIONS..... | 3 |
| 1.3 | SAFETY PRECAUTIONS DURING INSTALLATION..... | 3 |
| 1.4 | SAFETY PRECAUTIONS DURING OPERATION..... | 4 |
| 1.5 | SAFETY PRECAUTIONS DURING MAINTENANCE OR REPAIR..... | 5 |
| 1.6 | DISMANTLING AND DISPOSAL..... | 5 |
| 2 | General description..... | 7 |
| 2.1 | INTRODUCTION..... | 7 |
| 2.2 | OPERATION..... | 7 |
| 3 | Installation..... | 12 |
| 3.1 | DIMENSION DRAWING..... | 12 |
| 3.2 | INSTALLATION PROCEDURE..... | 13 |
| 4 | Operating instructions..... | 16 |
| 4.1 | PUTTING INTO OPERATION (COMMISSIONING)..... | 16 |
| 5 | Maintenance..... | 19 |
| 5.1 | MAINTENANCE..... | 19 |
| 5.2 | OPTIONS..... | 20 |
| 6 | Problem solving..... | 22 |
| 7 | Technical data..... | 23 |
| 7.1 | REFERENCE CONDITIONS AND LIMITATIONS..... | 23 |
| 7.2 | TECHNICAL DATA..... | 23 |

1 Safety precautions

1.1 Safety icons

Explanation

| | |
|---|----------------|
|  | Danger to life |
|  | Warning |
|  | Important note |

1.2 General safety precautions

| | |
|--|---|
|  | All responsibility for any damage or injury resulting from neglecting these precautions, or non-observance of the normal caution and care required for installation, operation, maintenance and repair, even if not expressly stated, will be disclaimed by the manufacturer. |
|--|---|

1. The operator must employ safe working practices and observe all related local work safety requirements and regulations.
2. If any of the following statements does not comply with local legislation, the stricter of the two shall apply.
3. Installation, operation, maintenance and repair work must only be performed by authorised, trained, specialised personnel.
4. Before carrying out any maintenance, repair work, adjustment or any other non-routine checks, stop the device. In addition, the power isolating switch must be opened and locked.

1.3 Safety precautions during installation

1. Install the equipment where the ambient air is cool and as clean as possible. Consult section Reference conditions and limitations.
2. During installation or any other intervention on the equipment or one of the connected machines, the machines must be stopped, de-energized and the isolating switch opened and locked before any maintenance or repair. As a further safeguard, persons switching on remotely controlled machines shall take adequate precautions to ensure that there is no one checking or working on the machine. To this end, a suitable notice shall be affixed to the start equipment.
3. Install the equipment in an area free of flammable fumes, vapours and particles, e.g. paint solvents, that can lead to internal fire or explosion.
4. The electrical connections must correspond to the applicable codes. The equipment must be earthed and protected against short circuits by fuses in all phases. A lockable power isolating switch must be installed near the equipment.
5. For machines controlled by a central control system, a sign stating "This machine may start without warning" must be affixed near the instrument panel.

6. In multiple compressor systems, manual valves must be installed to isolate each compressor. Non-return valves (check valves) must not be relied upon for isolating pressure systems.
7. Never remove or tamper with the safety devices.
8. If the maximum pressure of the compressor is higher than the design pressure of the connected equipment (e.g. a nitrogen generator or an oxygen generator), a full flow safety valve must be installed between the compressor and the connected equipment, in order to be able to blow off the excessive pressure.



Also consult following safety precautions: [Safety precautions during operation](#) and [Safety precautions during maintenance or repair](#).
 These precautions apply to electrical devices.
 For precautions applying to the connected equipment consult the relevant instruction book.
 Some precautions are general and cover several machine types and equipment; hence some statements may not apply to your device.

1.4 Safety precautions during operation



All responsibility for any damage or injury resulting from neglecting these precautions, or non-observance of the normal caution and care required for installation, operation, maintenance and repair, even if not expressly stated, will be disclaimed by the manufacturer.

1. Persons switching on remotely controlled machines shall take adequate precautions to ensure that there is no one checking or working on the machine. To this end, a suitable notice shall be affixed to the remote start equipment.
2. Never operate the device in the presence of flammable or toxic fumes, vapours or particles.
3. Never operate the device below or in excess of its limit ratings.
4. Do not operate the device when there are flammable or toxic fumes, vapors or particles.
5. Keep all bodywork doors and panels closed during operation. The doors may be opened for short periods only, e.g. to carry out routine checks.
6. People staying in environments or rooms where the sound pressure level reaches or exceeds 90 dB(A) shall wear ear protectors.
7. Periodically check that:
 - All guards and fasteners are in place and tight
 - All hoses and/or pipes are in good condition, secure and not rubbing
 - There are no leaks
 - All electrical leads are secure and in good order
8. Never remove or tamper with the safety devices.





Also consult following safety precautions: [Safety precautions during installation](#) and [Safety precautions during maintenance or repair](#).
 These precautions apply to electrical devices.
 For precautions applying to the connected equipment consult the relevant instruction book.
 Some precautions are general and cover several machine types and equipment; hence some statements may not apply to your machine.

1.5 Safety precautions during maintenance or repair

| | |
|---|--|
|  | <p>All responsibility for any damage or injury resulting from neglecting these precautions, or non observance of the normal caution and care required for installation, operation, maintenance and repair, even if not expressly stated, will be disclaimed by the manufacturer.</p> |
|---|--|

1. Use only the correct tools for maintenance and repair work.
2. Use only genuine spare parts.
3. A warning sign bearing a legend such as "Work in progress - do not start" shall be attached to the starting equipment, including all remote start equipment.
4. Persons switching on remotely controlled machines shall take adequate precautions to ensure that there is no one checking or working on the machine. To this end, a suitable notice shall be affixed to the remote start equipment.
5. Never use flammable solvents or carbon tetrachloride for cleaning parts. Take safety precautions against toxic vapors of cleaning liquids.
6. Scrupulously observe cleanliness during maintenance and repair. Keep dirt away by covering the parts and exposed openings with a clean cloth, paper or tape.
7. Never use a light source with open flame for inspecting the interior of the device.
8. All regulating and safety devices shall be maintained with due care to ensure that they function properly. They may not be put out of action.
9. Before clearing the device for use after maintenance or repair, check that operating pressures, temperatures and time settings are correct. Check that all control and shutdown devices are fitted and that they function correctly.
10. Make sure that no tools, loose parts or rags are left in or on the device.
11. Never use caustic solvents which can damage materials of the device.

| | |
|---|---|
|  | <p>Also consult following safety precautions: Safety precautions during installation and Safety precautions during operation. These precautions apply to electrical devices. For precautions applying to the connected equipment consult the relevant instruction book. Some precautions are general and cover several machine types and equipment; hence some statements may not apply to your machine.</p> |
|---|---|

| | |
|---|---|
|  | <p>Units and/or used parts must be disposed of in an environmentally friendly and safe manner and in line with the local recommendations and legislation.</p> |
|---|---|

1.6 Dismantling and disposal

Dismantling

Once the end of life of the machine is reached, please follow next steps:

1. Stop the machine.
2. Check all safety precautions mentioned in the previous chapters to secure safe handling (e.g. LOTO, cool-down, depressurize, discharge, ...).
3. Separate the harmful from the safe components (e.g. drain oil from oil containing parts).
4. Refer to the disposal topic mentioned below.

Disposal of electrical and electronic appliances (WEEE)

This equipment falls under the provisions of the European Directive 2012/19/EU on waste electrical and electronic appliances (WEEE) and may not be disposed as unsorted waste.



The equipment is labelled in accordance with the European Directive 2012/19/EU with the crossed-out wheellie bin symbol.

At the end of life-time of the electric and electronic equipment (EEE) it must be taken to separate collection.

For more information check with your local waste authority, customer center or distributor.

Disposal of other used material

Used filters or any other used material (e.g. filter bags, filter media, desiccant, lubricants, cleaning rags, machine parts, etc.) must be disposed of in an environmentally friendly and safe manner, and in line with the local recommendations and environmental legislation.

2 General description

2.1 Introduction

Compressed air produced by oil injected compressors contains a small quantity of oil. During the cooling of the air in the aftercooler and in the refrigeration dryer (if applicable), oil containing condensate is formed.

OSC are condensate treatment devices, designed to separate the major part of this oil from the condensate and absorb it in filters.

They are insensitive to shocks and vibration because of the use of filters and can be used with all types of drains. The condensate meets the requirements of the environmental codes.

The number in the model designation is the air capacity of the compressor in litres per second (see section [Technical data](#)).

OSC 12 and OSC 25 have two stages and are replaceable units.

OSC 50 up to OSC 625 have two stages and are serviceable units.

OSC 1250 and 2500 have three stages and are serviceable units.

2.2 Operation

OSC 12 – OSC 25

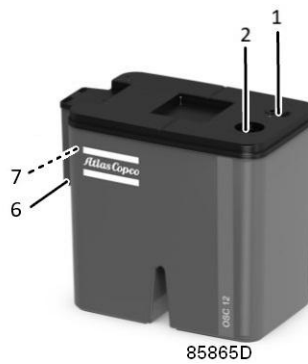

OSC 12 – OSC 25

| | |
|---|-----------------------|
| 1 | Condensate inlet |
| 2 | Depressurization vent |
| 6 | Condensate outlet |
| 7 | Test outlet |

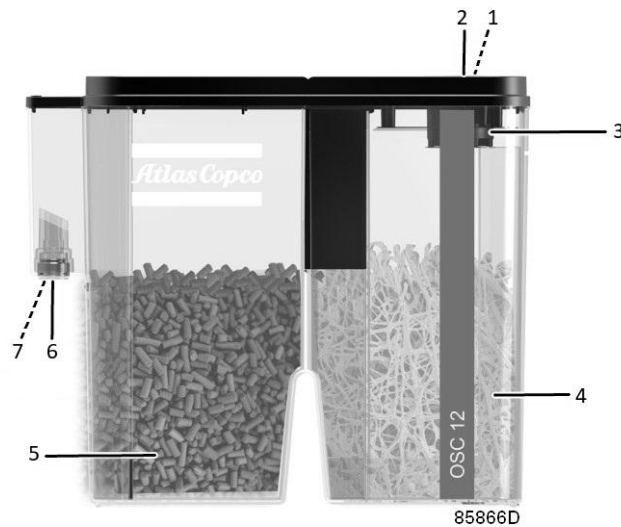

Flow diagram OSC 12 – OSC 25

| | |
|---|--|
| 1 | Condensate inlet |
| 2 | Pressure relief vent |
| 3 | Muffler |
| 4 | Oleophilic filter (first stage) |
| 5 | Activated carbon/ organoclay filter (second stage) |
| 6 | Condensate outlet |
| 7 | Test outlet |

The condensate, containing fine oil droplets, enters the unit via inlet (1) into the mufflers (3) and is depressurized. The condensate flows to the first stage and seeps through an oleophilic filter (4), which absorbs most of the oil.

The water from the first tower, still containing a small quantity of oil, gradually flows to a second stage, where an activated carbon/organoclay filter (5) is fitted. This filter absorbs almost all of the remaining oil.

The clean condensate is drained to the condensate outlet (6).

OSC 50 – OSC 625

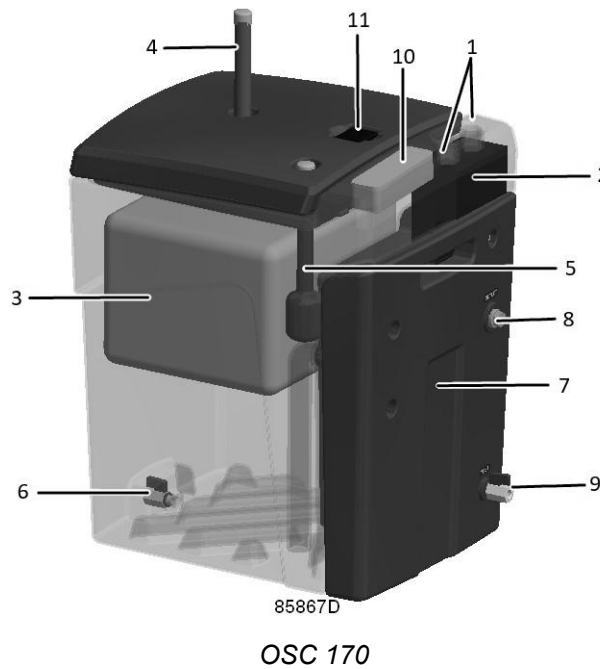

| | |
|----|---|
| 1 | Condensate inlet |
| 2 | Mufflers |
| 3 | Oleophilic filters (first stage) |
| 4 | Service indicator (oleophilic filter) |
| 5 | Service indicator (unit clogged) |
| 6 | Drain |
| 7 | Activated carbon/ organoclay filters (second stage) |
| 8 | Condensate outlet |
| 9 | Test valve |
| 10 | Diffuser |
| 11 | Test capsule storage compartment |

The condensate, containing fine oil droplets, enters the unit via the Inlet (1) into the mufflers (2) and is depressurized. The condensate flows to the first tower and seeps through an oleophilic filter (3), which absorbs most of the oil.

The water from the first stage, still containing a small quantity of oil, gradually flows to a second stage, where an activated carbon filter/ organoclay filter (depending on variant) is fitted (7). The second stage filter starts to absorb the remaining oil in the condensate.

The clean condensate is drained to the condensate outlet (8).

The oleophilic filter floats on the water. The more oil the filter absorbs, the deeper it will sink, and service indicator (4) will move downwards with the filter. The filter must be replaced when the service indicator is down.



OSC 1250 – OSC 2500

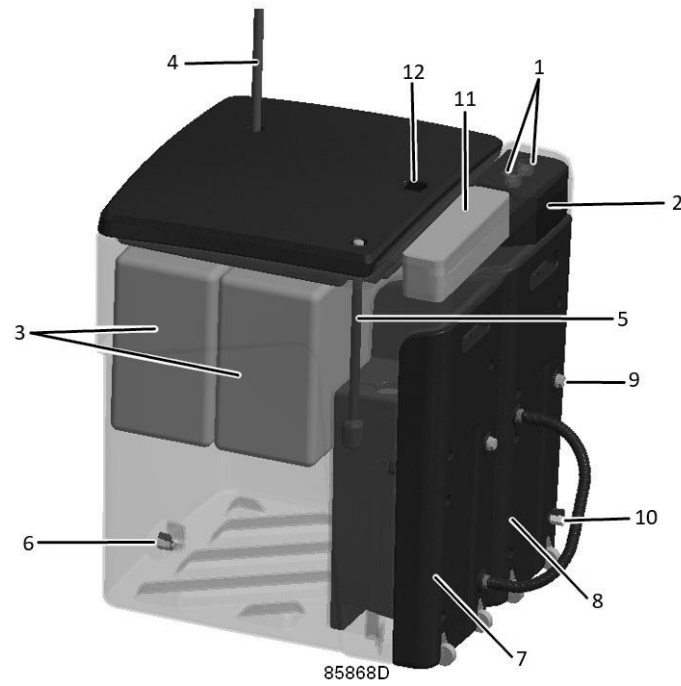

OSC 1250

| | |
|---|---------------------------------------|
| 1 | Condensate inlet |
| 2 | Mufflers |
| 3 | Oleophilic filters (first stage) |
| 4 | Service indicator (oleophilic filter) |
| 5 | Service indicator (unit clogged) |
| 6 | Drain |

| | |
|----|---|
| 7 | Activated carbon/ organoclay filters (second stage) |
| 8 | Activated carbon/ organoclay filters (second stage) |
| 9 | Condensate outlet |
| 10 | Test valve |
| 11 | Diffuser |
| 12 | Test capsule storage compartment |

The condensate, containing fine oil droplets, enters the unit via inlets (1) into the mufflers (2) and is depressurized. The condensate flows to the first tower and seeps through an oleophilic filter (3), which absorbs most of the oil.

The water from the first stage, still containing a small quantity of oil, gradually flows to a second stage, where an activated carbon filter/ organoclay filter (depending on variant) is fitted (7). The second stage filter starts to absorb the part of the oil in the condensate. The condensate gradually flows into the third stage where another activated carbon filter/ organoclay filter (depending on variant) is fitted (8).

The clean condensate is drained to the condensate outlet (9).

The oleophilic filter floats on the water. The more oil the filter absorbs, the deeper it will sink, and service indicator (4) will move downwards with the filter. The filter must be replaced when the service indicator is down.



OSC 2500 consists of two units and a flow divider needs to be installed to feed both units equal amount of condensate.

3 Installation

3.1 Dimension drawing

The dimension drawing can be found on the USB which is supplied with the unit.

OSC 12 – OSC 25

| Model | Push fit connection size | |
|--------|--------------------------|--------------------------|
| | Inlet (metric/imperial) | Outlet (metric/imperial) |
| OSC 12 | 1 x 6 mm (1/4 ") | 1 x 10 mm (3/8 ") |
| OSC 25 | 1 x 6 mm (1/4 ") | 1 x 10 mm (3/8 ") |

OSC 50 – OSC 2500

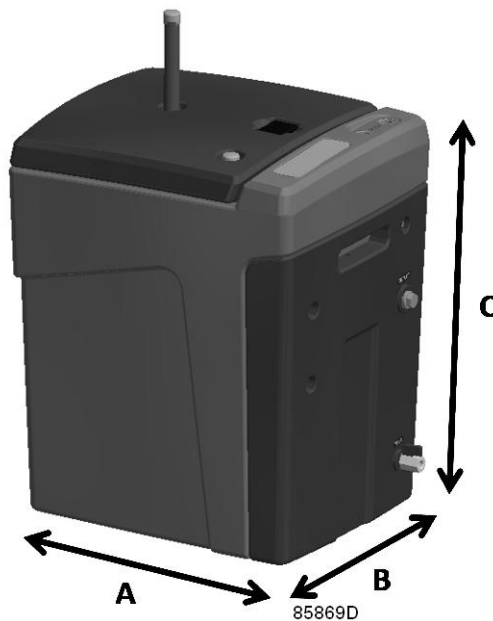

| | | OSC 50 | OSC 85 | OSC 170 | OSC 300 | OSC 625 | OSC 1250 | OSC 2500 |
|----------------------|---------------------------------|--------|--------|---------|---------|---------|----------|----------|
| A (mm) | Activated carbon/ Organoclay | 390 | 397 | 490 | 583 | 692 | 975 | 975 |
| A (inch) | | 15 | 16 | 19 | 23 | 27 | 38 | 38 |
| B (mm) | | 278 | 286 | 396 | 446 | 568 | 782 | 1600 |
| B (inch) | | 11 | 11 | 16 | 18 | 22 | 31 | 63 |
| C (mm) | | 428 | 507 | 576 | 721 | 970 | 1000 | 1000 |
| C (inch) | | 17 | 20 | 23 | 28 | 38 | 39 | 39 |
| Shipping weight (kg) | Activated carbon | 6.8 | 10 | 15 | 28 | 48 | 89 | 175 |
| Shipping weight (lb) | | 15 | 21 | 33 | 62 | 106 | 196 | 386 |

| | | OSC 50 | OSC 85 | OSC 170 | OSC 300 | OSC 625 | OSC 1250 | OSC 2500 |
|-----------------------|------------------|---------------|---------------|----------------|----------------|----------------|-----------------|-----------------|
| Shipping weight (kg) | Organoclay | 7.5 | 11 | 17 | 32 | 56 | 104 | 205 |
| Shipping weight (lb) | | 17 | 24 | 38 | 71 | 123 | 229 | 451 |
| Operating weight (kg) | Activated carbon | 13.7 | 19 | 36 | 63 | 113 | 207 | 413 |
| Operating weight (lb) | | 30 | 42 | 79 | 138 | 249 | 455 | 911 |
| Operating weight (kg) | Organoclay | 14.4 | 20 | 38 | 67 | 121 | 221 | 443 |
| Operating weight (lb) | | 32 | 45 | 84 | 147 | 266 | 488 | 976 |

| Model | Connections | |
|--------------|----------------------|-----------------------|
| | Inlet BSP/NPT | Outlet BSP/NPT |
| OSC 50 | 2 x 1/2 " | 1 x 1/2 " |
| OSC 85 | 2 x 1/2 " | 1 x 1/2 " |
| OSC 170 | 2 x 1/2 " | 1 x 1/2 " |
| OSC 300 | 2 x 3/4 " | 1 x 3/4 " |
| OSC 625 | 2 x 3/4 " | 1 x 3/4 " |
| OSC 1250 | 2 x 3/4 " | 1 x 3/4 " |
| OSC 2500 | 2 x 3/4 " | 2 x 3/4 " |

3.2 Installation procedure

OSC 12 – OSC 25

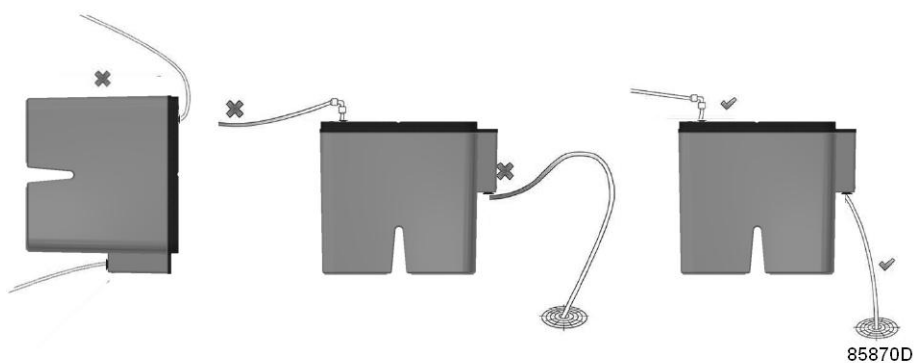

Always install the device as shown in the pictures, i.e. vertically.

It is advised that the drain tube from the compressor installation to the oil/water separator inclines downwards over the entire tubing length. This will prevent local accumulations and stagnation of condensate pockets in the tubing. Some types of drains depressurize the condensate by means of a nozzle, removing the propulsion force of the pressure to inject the condensate in the

separator. For this reason, it is advised to position the separator lower than the drains that are feeding it, whenever possible.

The drain tube that is mounted to the outlet of the oil/water separator must incline downwards over its entire length. The reason for this is to avoid accumulation of water pockets in the tubing and to prevent flooding of the oil/water separator, should the outlet tubing get higher than the outlet connection. The use of manual drains should be considered with care, as opening this type of drain for too long may flood the oil/water separator by exceeding its depressurizing capacity. Therefore it is advised not to use manual drains on the oil/water separator.

It is advised to connect only 1 compressor, dryer or filter per oil/water separator. If multiple drains of the same compressor installation (after cooler, integrated dryer, filters, etc.) are connected to the same oil/water separator, special attention has to be given so that these drains push their condensate in the oil/water separator rather than into each other.

OSC 50 – OSC 625

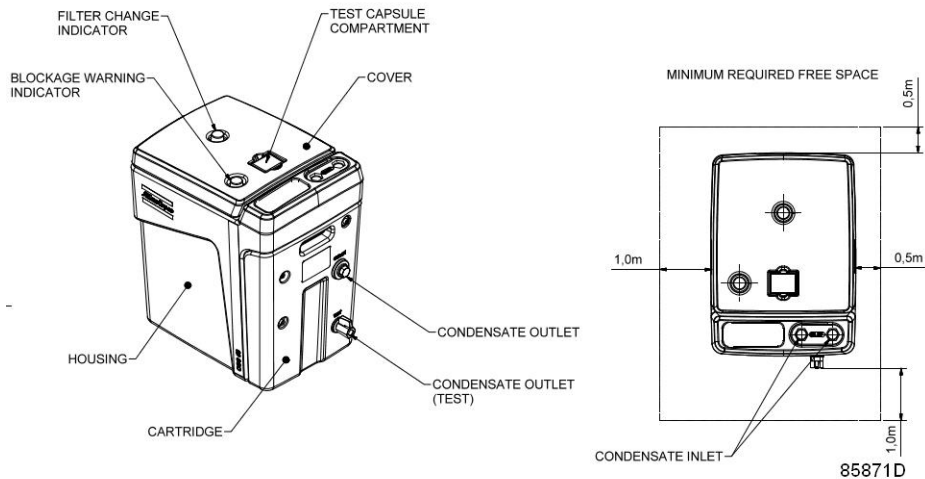

OSC 1250

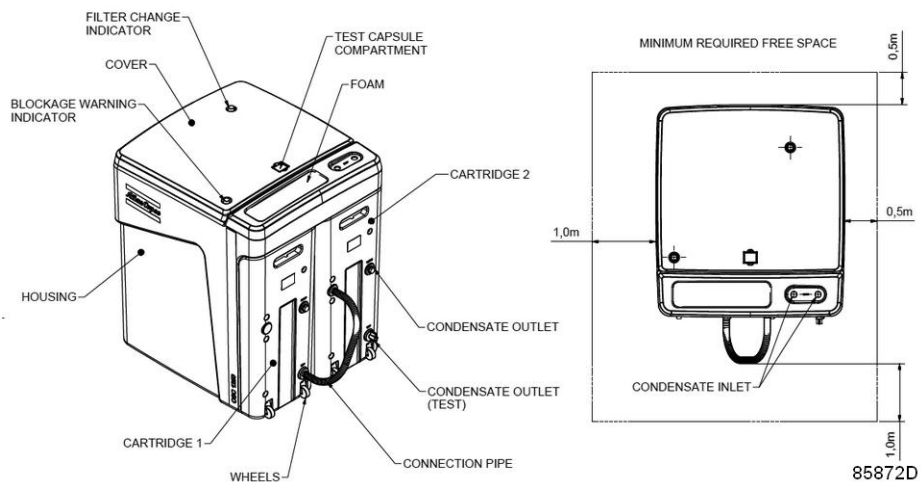

OSC 2500

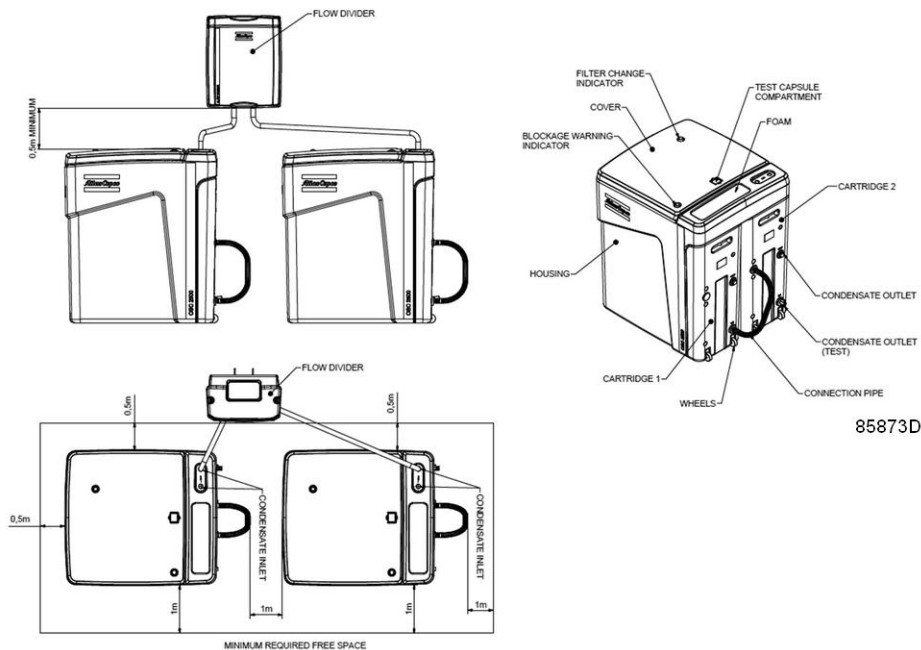

Procedure

| | |
|--|---|
| | <p>The unit must be positioned higher than the sewer and the outlet piping of the unit must be installed with a slight downward slope to the sewer.</p> |
|--|---|

1. Install the unit on a level floor, suitable for taking its weight.
Keep in mind to reserve enough free space for replacement of the filters (see section [Maintenance](#)).
2. Stop the compressor and close the air outlet valve. Switch off the voltage. Depressurize the outlet piping by opening the manual condensate drain.
3. Connect the automatic drain of the compressor condensate trap to the condensate inlet of the unit.
The connection can be made using one or both condensate inlets. The piping diameter must be at least 6 mm for OSC 12-25, 10 mm for OSC 50-300 and 20 mm for OSC 625-2500. The flexible must be laid out in such a way that no pockets are formed where condensate can collect.
4. Connect the condensate outlet of the unit to the sewer.
The outlet piping should have a section, sufficient to allow the condensate to flow without building up pressure. An inner diameter of 19 mm (3/4 ") or larger is recommended. See section [Dimension drawing](#) for the connection dimensions.

4 Operating instructions

4.1 Putting into operation (commissioning)



The plastic bag of the filters must be removed. Do not remove the net around the filters.

OSC 50 – OSC 625

1. Remove the lid of the housing. Take out the oleophilic filter.
2. Remove the cartridge by removing 3 screws (6mm cross head).
Remove the protecting plug from the cartridge hose and the black plastic plug over the outlet location as shown in below figure (1, 2).
Place the cartridge back and secure it with screws. Make sure that the o-ring is inserted properly.

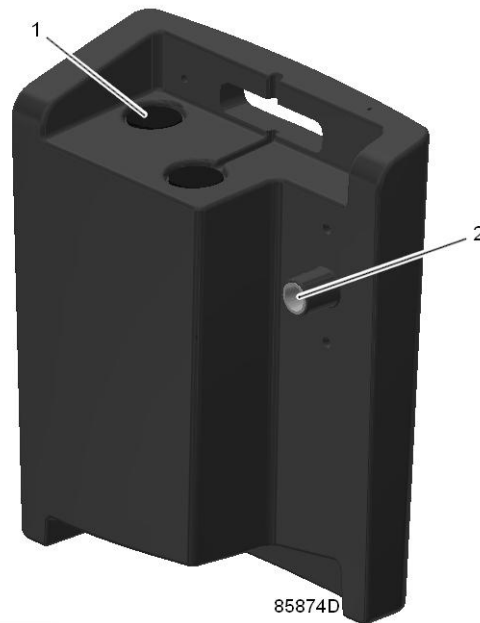

3. Check that the muffler is placed properly and exactly below the condensate inlets.
4. Pour clean water into the unit until the water comes out of the condensate outlet.
5. Put the oleophilic filter on the water surface in the housing. **Do not push the filter down.**
6. Put back the lid and check that the service indicator is free to move.

OSC 1250

1. Remove the lid of the housing. Take out the oleophilic filter.
2. Remove the cartridge by removing 4 screws (6mm cross head).
Remove the protecting plug from the cartridge hose (only on the first cartridge) and the black plastic plug over the outlet location as shown in below figure (1, 2).
Place the cartridge back and secure it with screws. Make sure that the o-ring is inserted properly.

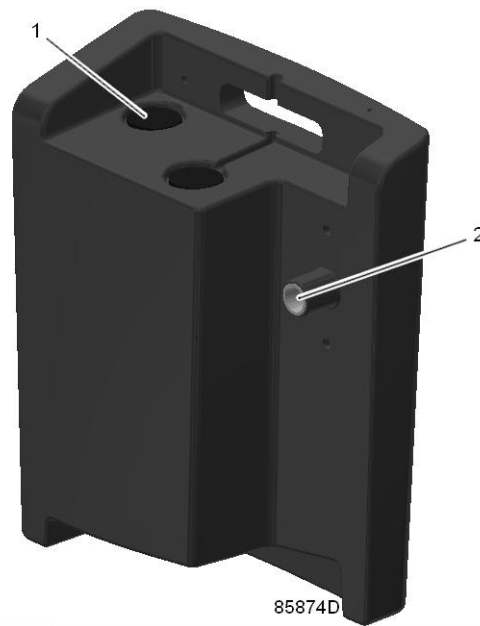

3. Make a connection using flexible hose between both cartridges as shown in below figure.



4. One of the connection on the first cartridge should always remain closed.
5. Check that the muffler is place properly and exactly below the condensate inlets.
6. Pour clean water into the unit until the water comes out of the condensate outlet.
7. Put the oleophilic filter on the water surface in the housing. **Do not push the filter down.**
8. Put back the lid and check that the service indicator is free to move.

OSC 2500

1. OSC 2500 consists of two identical units and a flow divider.
2. The steps in section OSC 1250 must be followed on each unit.
3. A flow divider must be installed on a wall at a level minimum 0.5 m above the OSC units.
4. The flow divider has two outlets, each one must be connected to the condensate inlet of the separate units. Make sure that there are no traps for the condensate to collect.

5 Maintenance

5.1 Maintenance

| | |
|---|---|
|  | <p>Check the filters regularly as explained below in order to prevent untreated condensate from entering the sewer. Sample the condensate weekly.</p> |
|---|---|

| | |
|---|---|
|  | <ul style="list-style-type: none"> • If the filters are not installed properly, oil-containing condensate can leave the OSC. • When new activated carbon filters are placed, the outgoing water may initially look black (caused by carbon dust). This is not harmful. • Each new filter is provided with a label. The correct position is marked on the label. • Used filters can be heavy. • See to it that no condensate comes into contact with eyes, mouth, ... |
|---|---|

Checking the condensate

Every week, a test sample should be collected during compressor operation.

1. Open the test valve and collect the condensate in the test capsule stored in the compartment on the cover.
2. Compare the turbidity of the sample with the 10 ppm reference side on the test capsule.

| | |
|---|---|
|  | <p>Test capsules for OSC 12 – OSC 25 are provided as an option. A ball valve with stem connection can be installed at the test push fit connection beside the outlet to easily tap a test sample.</p> |
|---|---|

Oleophilic filter

| | |
|---|--|
|  | <p>If the activated carbon filter has to be replaced, do this first (see section Activated carbon filters).</p> |
|---|--|

Initially, the oleophilic filter will float almost completely on the condensate and only the bottom part will act as filtration medium. By sorbing more and more oil, the filter will sink and new filter material will be exposed to the condensate.

The filter must be replaced when the service indicator (see section [Introduction](#)) approaches the lid of the housing or when the condensate from the test outlet is less transparent than in the reference test capsule.

The lifetime of the filter depends on the amount of oil in the condensate.

Both filters should be replaced while servicing the unit. Filters should be replaced at least once per year irrespective of the loading.

Replacement instructions

1. Stop the compressor and close the air outlet valve. Switch off the voltage. Depressurize the outlet piping by opening the manual condensate drain.
2. Remove the lid of the housing and take out the oleophilic filter.

3. **Only if necessary** (see [Problem solving, item 1](#)), clean the inside of the condensate treatment device with water and tissue.
Do not use any form of soap or detergents as they could contain dispersants which deteriorate the ability to break oil/water emulsions.
4. Remove the diffuser and pull out the mufflers. See section [Introduction](#).
5. Fit the new mufflers and diffuser.
6. Go to section [Activated carbon/ organoclay filter, Replacement instructions](#).
7. Fit the new filter (white label), observing the position. **Do not push the filter below the water surface.**
8. Fit the cover on the housing.

On OSC 2500: Repeat the instructions once for the left side of the unit and once for the right side of the unit.

Activated carbon/ organoclay filter

Replacement instructions

1. Open the test valve and empty the cartridge into a bucket. Drained condensate can be poured back into the housing later.
2. Remove the screws of the cartridge and pull it away from the housing. It is not required to lift the cartridge of OSC 625 – OSC 2500 as they are provided with wheels.
3. Remove the ball valve at test outlet and place it to the new cartridge.
4. Remove the plugs from the new cartridge and place them to used one. This would make the used cartridge leak tight.
5. Place the cartridge near housing close to housing almost at installation location but enough gap to fill the new cartridge with clean water. Start filling the cartridge till the water starts flowing out of the condensate outlet.
6. Push the cartridge into the housing and secure it with screws.
7. Pour back the drained condensate in the first step into the housing.
8. Fill the housing with clean water till water starts flowing out of condensate outlet.
9. Inspect for leaks at the connection between housing and cartridge.
10. Go back to [Oleophilic filter, Replacement instructions](#).

5.2 Options

Alarm

Optional electronic alarm sensors are available warning the operator for condensate overflow and filter replacement.

| | |
|-------|--------------|
| Alarm | 8092 2849 29 |
|-------|--------------|

Manifold

An optional manifold is available for easy connection of several condensate lines into the unit.

| | |
|-------------------------------------|--------------|
| Manifold for OSC 50 up to OSC 170 | 8070 2167 03 |
| Manifold for OSC 300 up to OSC 1250 | 8070 2167 11 |

Sampling kit for OSC 12 – OSC 25

An optional sampling kit is available to test the outlet turbidity.

| | |
|-------------------------|------------|
| Sampling kit (metric) | 8102047010 |
| Sampling kit (imperial) | 8102047011 |

Wall mounting bracket for OSC 12 – OSC 25

An optional wall mounting bracket is available to mount the unit on the wall.

| | |
|-----------------------|------------|
| Wall mounting bracket | 8102047000 |
|-----------------------|------------|

6 Problem solving

| Condition | Fault | Remedy |
|--|---|---|
| A lot of oil entered the OSC. | Compressor malfunctioning | Replace all filters. Clean the vessels. Check the compressor. |
| The service indicator (5 - View of the unit) rises | Too much condensate flows into the OSC. | Check the compressor FAD (see section Technical data). |



7 Technical data

7.1 Reference conditions and limitations

Reference conditions

| | | |
|--|------------------|---|
| Effective working pressure of the compressor | bar(e) | 13 |
| Effective working pressure of the compressor | psig | 190 |
| Compressor running hours per day | h | 12 |
| Oil type | Activated carbon | Roto-Inject Fluid, Roto-Synthetic Ultra or any other mineral oil. |
| | Organoclay | Roto-Xtend Duty Fluid, Roto-Foodgrade Fluid or any other synthetic oil. |
| Compressor type | | All types of GA oil injected compressors |

The reference conditions for the OSC distinguish 3 climate types:

- Cold climate: ambient temperature of 15 °C (59 °F) and relative humidity of 60 %
- Mild climate: ambient temperature of 25 °C (77 °F) and relative humidity of 60%
- Hot climate: ambient temperature of 35 °C (95 °F) and relative humidity of 70%

Limitations for operation

| | | |
|--|------|-------|
| Minimum inlet temperature | °C | 1 |
| Minimum inlet temperature | °F | 33.80 |
| Minimum ambient temperature | °C | 1 |
| Minimum ambient temperature | °F | 33.80 |
| Maximum condensate inlet temperature | °C | 75 |
| Maximum condensate inlet temperature | °F | 167 |
| Maximum oil content at outlet of the OSC | mg/l | 10 |

7.2 Technical data

Compressor FAD

| | |
|---|--|
|  | For poly-glycol based condensates, the capacity of each unit should be halved. |
|---|--|

Installation with compressors, air receivers, filters and dryers:

| Models | | OSC 12 | OSC 25 | OSC 50 | OSC 85 | OSC 170 | OSC 300 | OSC 625 | OSC 1250 | OSC 2500 |
|--------------|-----|--------|--------|--------|--------|---------|---------|---------|----------|----------|
| Cold climate | l/s | 16 | 33 | 67 | 113 | 227 | 400 | 833 | 1666 | 3332 |

| Models | | OSC 12 | OSC 25 | OSC 50 | OSC 85 | OSC 170 | OSC 300 | OSC 625 | OSC 1250 | OSC 2500 |
|--------------|-----|--------|--------|--------|--------|---------|---------|---------|----------|----------|
| Cold climate | cfm | 34 | 71 | 141 | 240 | 480 | 848 | 1766 | 3532 | 7065 |
| Mild climate | l/s | 12 | 25 | 50 | 85 | 170 | 300 | 625 | 1250 | 2500 |
| Mild climate | cfm | 25 | 53 | 106 | 180 | 360 | 636 | 1325 | 2650 | 5300 |
| Hot climate | l/s | 6 | 12 | 24 | 41 | 83 | 146 | 304 | 608 | 1216 |
| Hot climate | cfm | 13 | 26 | 52 | 88 | 175 | 309 | 645 | 1289 | 2578 |

Installation with compressors, air receivers and filters:

| Models | | OSC 12 | OSC 25 | OSC 50 | OSC 85 | OSC 170 | OSC 300 | OSC 625 | OSC 1250 | OSC 2500 |
|--------------|-----|--------|--------|--------|--------|---------|---------|---------|----------|----------|
| Cold climate | l/s | 20 | 42 | 63 | 142 | 283 | 500 | 1042 | 2083 | 4167 |
| Cold climate | cfm | 42 | 88 | 133 | 300 | 601 | 1060 | 2208 | 4417 | 8833 |
| Mild climate | l/s | 15 | 31 | 63 | 106 | 213 | 375 | 781 | 1563 | 3125 |
| Mild climate | cfm | 32 | 66 | 133 | 225 | 451 | 795 | 1656 | 3313 | 6625 |
| Hot climate | l/s | 9 | 17 | 34 | 57 | 114 | 201 | 420 | 839 | 1678 |
| Hot climate | cfm | 18 | 36 | 71 | 121 | 242 | 427 | 890 | 1779 | 3558 |

Correction factors

For operation in other than reference conditions, multiply the compressor capacity (FAD) in the above tables with the appropriate correction factors.

| Running hours per day | 12 | 14 | 16 | 18 | 20 | 22 | 24 |
|-----------------------|------|------|------|------|-----|------|-----|
| Correction factor | 1.00 | 0.86 | 0.75 | 0.67 | 0.6 | 0.55 | 0.5 |

The condensate treatment device is designed to operate 12-hour duty cycles or less. If the compressor is running more than 12 hour per day the appropriate correction factor must be considered.

Separation performance

For an outlet oil carry-over of 5 mg/l instead of 10 mg/l, multiply the compressor capacity (FAD) in the above tables by 1/2.

COMMITTED TO SUSTAINABLE PRODUCTIVITY

We stand by our responsibilities towards our customers, towards the environment and the people around us. We make performance stand the test of time. This is what we call — Sustainable Productivity.

www.atlascopco.com

