

# **INSTRUCTION BOOK**

## **HEATLESS ADSORPTION AIR DRYERS**

CD 25, CD 35, CD 45, CD 55, CD 65, CD 90, CD 110, CD 130, CD 165, CD 195,  
CD 260

*Atlas Copco*





# Atlas Copco

## Heatless adsorption air dryers

CD 25, CD 35, CD 45, CD 55, CD 65, CD 90, CD 110,  
CD 130, CD 165, CD 195, CD 260

### Instruction book

Original instructions

#### **COPYRIGHT NOTICE**

Any unauthorized use or copying of the contents or any part thereof is prohibited.

This applies in particular to trademarks, model denominations, part numbers and drawings.

This instruction book is valid for CE as well as non-CE labelled machines. It meets the requirements for instructions specified by the applicable European directives as identified in the Declaration of Conformity.

2021 - 08

No. 2920 7111 13

[www.atlascopco.com](http://www.atlascopco.com)



# Table of contents

|          |  |           |
|----------|--|-----------|
| <b>1</b> | <b>Safety precautions.....</b>                       | <b>5</b>  |
| 1.1      | SAFETY ICONS.....                                    | 5         |
| 1.2      | SAFETY PRECAUTIONS, GENERAL.....                     | 5         |
| 1.3      | SAFETY PRECAUTIONS DURING INSTALLATION.....          | 6         |
| 1.4      | SAFETY PRECAUTIONS DURING OPERATION.....             | 7         |
| 1.5      | SAFETY PRECAUTIONS DURING MAINTENANCE OR REPAIR..... | 8         |
| 1.6      | DISMANTLING AND DISPOSAL.....                        | 9         |
| <b>2</b> | <b>General description.....</b>                      | <b>11</b> |
| 2.1      | GENERAL DESCRIPTION.....                             | 11        |
| 2.2      | OPERATION.....                                       | 12        |
| <b>3</b> | <b>Electric diagram.....</b>                         | <b>15</b> |
| <b>4</b> | <b>DC1 controller.....</b>                           | <b>16</b> |
| 4.1      | CONTROL PANEL.....                                   | 16        |
| 4.2      | MAIN SCREEN.....                                     | 17        |
| 4.3      | SELECTION MENU.....                                  | 18        |
| 4.4      | ALARM SCREEN.....                                    | 19        |
| 4.5      | EDITING PARAMETERS.....                              | 20        |
| <b>5</b> | <b>Graphic controller.....</b>                       | <b>23</b> |
| 5.1      | GENERAL .....  | 23        |
| 5.2      | CONTROL PANEL.....                                   | 24        |
| 5.3      | ICONS USED.....                                      | 25        |
| 5.4      | MAIN SCREEN.....                                     | 28        |
| 5.5      | CALLING UP MENUS.....                                | 32        |
| 5.6      | INPUTS MENU.....                                     | 33        |



|           |                                    |           |
|-----------|------------------------------------|-----------|
| 5.7       | OUTPUTS MENU.....                  | 34        |
| 5.8       | COUNTERS.....                      | 35        |
| 5.9       | EVENT HISTORY MENU.....            | 37        |
| 5.10      | TEST MENU.....                     | 38        |
| 5.11      | SERVICE MENU.....                  | 39        |
| 5.12      | PROTECTIONS MENU.....              | 43        |
| 5.13      | WEEK TIMER MENU.....               | 44        |
| 5.14      | INFO MENU.....                     | 54        |
| 5.15      | MODIFYING SETTINGS.....            | 54        |
| 5.16      | EXTRA MENU.....                    | 60        |
| 5.17      | WEB SERVER.....                    | 62        |
| 5.18      | PROGRAMMABLE SETTINGS.....         | 71        |
| <b>6</b>  | <b>Installation.....</b>           | <b>72</b> |
| 6.1       | DIMENSION DRAWINGS.....            | 72        |
| 6.2       | INSTALLATION PROPOSAL.....         | 72        |
| <b>7</b>  | <b>Electrical connections.....</b> | <b>76</b> |
| <b>8</b>  | <b>Operating instructions.....</b> | <b>77</b> |
| <b>9</b>  | <b>Maintenance.....</b>            | <b>79</b> |
| 9.1       | MAINTENANCE.....                   | 79        |
| 9.2       | NOZZLE REPLACEMENT.....            | 80        |
| <b>10</b> | <b>Problem solving.....</b>        | <b>82</b> |
| <b>11</b> | <b>Technical data.....</b>         | <b>83</b> |
| 11.1      | REFERENCE CONDITIONS.....          | 83        |
| 11.2      | LIMITATIONS FOR OPERATION.....     | 83        |
| 11.3      | DRYER DATA.....                    | 84        |

|           |   |           |
|-----------|---|-----------|
| <b>12</b> | <b>Instructions for use.....</b>          | <b>89</b> |
| <b>13</b> | <b>Guidelines for inspection.....</b>     | <b>90</b> |
| <b>14</b> | <b>Pressure Equipment Directives.....</b> | <b>91</b> |
| <b>15</b> | <b>Declaration of conformity.....</b>     | <b>92</b> |

# 1 Safety precautions

## 1.1 Safety icons

### Explanation

|   |                |
|---|----------------|
|  | Danger to life |
|  | Warning        |
|  | Important note |

## 1.2 Safety precautions, general

### General precautions

|   |   |
|---|---|
|  | All responsibility for any damage or injury resulting from neglecting these precautions, or non-observance of the normal caution and care required for installation, operation, maintenance and repair, even if not expressly stated, will be disclaimed by the manufacturer. |
|---|---|

1. The dryers are designed for normal indoor use.
2. The operator must employ safe working practices and observe all related work safety requirements and regulations.
3. If any of the following statements does not comply with the applicable legislation, the stricter of the two shall apply.
4. Installation, operation, maintenance and repair work must only be performed by authorized, trained, specialized personnel.
5. The dryer is not considered capable of producing air of breathing quality. To obtain air of breathing quality, the compressed air must be adequately purified according to the applicable legislation and standards.
6. Before any maintenance, repair work, adjustment or any other non-routine checks, stop the dryer, press the emergency stop button, switch off the voltage and depressurize the dryer. In addition, the power isolating switch must be opened and locked. For plug versions, remove the plug from the wall socket and secure it.
7. Never play with compressed air. Do not apply the air to your skin or direct an air stream at people. Never use the air to clean dirt from your clothes. When using the air to clean equipment, do so with extreme caution and wear eye protection.
8. The owner is responsible for maintaining the dryer in safe operating condition. Parts and accessories shall be replaced if unsuitable for safe operation.
9. It is not allowed to walk or stand on the dryer or its components.

## 1.3 Safety precautions during installation

### Precautions during installation

1. The dryer must only be lifted using suitable equipment and in accordance with the applicable safety regulations. Loose or pivoting parts must be securely fastened before lifting. It is strictly forbidden to dwell or stay in the risk zone under a lifted load. Lifting acceleration and deceleration must be kept within safe limits. Wear a safety helmet when working in the area of overhead or lifting equipment.
2. Place the dryer where the ambient air is as cool and clean as possible. If necessary, install a suction duct. Never obstruct the air inlet. Care must be taken to minimize the entry of humidity in the inlet air.
3. Any blanking flanges, plugs, caps or desiccant bags must be removed before connecting the pipes.
4. Air hoses must be of correct size and suitable for the working pressure. Never use frayed, damaged or worn hoses. Distribution pipes and connections must be of the correct size and suitable for the working pressure.
5. The aspirated air must be free of flammable fumes, vapors and particles, e.g. paint solvents, that can lead to internal fire or explosion.
6. Arrange the air intake so that loose clothing worn by people cannot be sucked in.
7. Ensure that all piping is free to expand under heat and that it is not in contact with or close to flammable materials.
8. No external force may be exerted on the air outlet valve. The connected pipe must be free of strain.
9. If remote control is installed, the machine must bear a clear sign stating "Danger: This machine is remotely controlled and may start without warning".  
The operator has to make sure that the machine is stopped and that the isolating switch is open and locked before any maintenance or repair. As a further safeguard, persons switching on remotely controlled machines shall take adequate precautions to ensure that there is no one checking or working on the machine. To this end, a suitable notice shall be affixed to the starting equipment.
10. Air-cooled machines must be installed in such a way that an adequate flow of cooling air is available and that the exhausted cooling air does not recirculate to the inlet.
11. The electrical connections must correspond to the applicable codes. The machines must be earthed and protected against short circuits by fuses in all phases. A lockable power isolating switch must be installed near the equipment.
12. On machines with automatic start-stop system or if the automatic restart function after voltage failure is activated, a sign stating "This machine may start without warning" must be affixed near the instrument panel.
13. Never remove or tamper with the safety devices, guards or insulation fitted on the machine. Every pressure vessel or auxiliary installed outside the machine to contain air above atmospheric pressure must be protected by a pressure-relieving device or devices as required.
14. Piping or other parts with a temperature in excess of 80°C (176°F) and which may be accidentally touched by personnel during normal operation must be guarded or insulated. Other high-temperature piping must be clearly marked.
15. For water-cooled machines, the cooling water system installed outside the machine has to be protected by a safety device with set pressure according to the maximum cooling water inlet pressure.
16. If no safety valve is present in the air net close to the desiccant dryer (e.g. safety valve of compressor), full flow safety valves must be installed on the dryer vessels.

17. If the maximum pressure of the compressor is higher than the design pressure of the dryer, a full flow safety valve must be installed between the compressor and the dryer in order to blow off the excessive pressure. This is done in case the safety valve of the dryer is out of order or blocked.
18. When unit is not permanently secured to the floor in the vertical position or mounted vertically, access to electrical equipment is feasible through the unit base. In this case, additional barriers must be provided during installation. Tag with "Warning: High Voltage" symbol



Also consult following safety precautions: [Safety precautions during operation](#) and [Safety precautions during maintenance or repair](#).

These precautions apply to machinery processing or consuming air or inert gas. Processing of any other gas requires additional safety precautions typical to the application which are not included herein.

Some precautions are general and cover several machine types and equipment; hence some statements may not apply to your machine.

## 1.4 Safety precautions during operation

### Precautions during operation

1. Always be careful when touching any piping or components of the dryer during operation. On dryers using heat to regenerate the desiccant, some parts will become very hot.
2. Use only the correct type and size of hose end fittings and connections. When blowing through a hose or air line, ensure that the open end is held securely. A free end will whip and may cause injury. Make sure that a hose is fully depressurized before disconnecting it.
3. Persons switching on remotely controlled machines shall take adequate precautions to ensure that there is no one checking or working on the machine. To this end, a suitable notice shall be affixed to the remote start equipment.
4. Never operate the machine when there is a possibility of taking in flammable or toxic fumes, vapors or particles.
5. Never operate the machine below or in excess of its limit ratings.
6. Keep all bodywork closed during operation. Bodywork should be opened for short periods only, e.g. to carry out routine checks. Wear ear protectors when removing a panel.
7. People staying in environments or rooms where the sound pressure level reaches or exceeds 90 dB(A) shall wear ear protectors.
8. Periodically check that:
  - All guards are in place and securely fastened
  - All hoses and/or pipes inside the machine are in good condition, secure and not rubbing
  - There are no leaks
  - All fasteners are tight
  - All electrical leads are secure and in good order
  - Safety valves and other pressure relief devices are not obstructed by dirt or paint
  - Air outlet valve and air net, i.e. pipes, couplings, manifolds, valves, hoses, etc. are in good condition, free of wear or abuse
9. If warm cooling air from dryers is used in air heating systems, e.g. to warm up a working area, take precautions against air pollution and possible contamination of the breathing air.
10. Do not remove any of, or tamper with, the sound dampening material.
11. Never remove or tamper with the safety devices, guards or insulations fitted on the machine. Every pressure vessel or auxiliary installed outside the machine to contain air above

atmospheric pressure shall be protected by a pressure relieving device or devices as required.

12. Yearly inspect the air receiver. Minimum wall thickness as specified in the instruction book must be respected. Local regulations remain applicable if they are more strict.



Also consult following safety precautions: [Safety precautions during installation](#) and [Safety precautions during maintenance or repair](#).  
These precautions apply to machinery processing or consuming air or inert gas. Processing of any other gas requires additional safety precautions typical to the application which are not included herein.  
Some precautions are general and cover several machine types and equipment; hence some statements may not apply to your machine.

## 1.5 Safety precautions during maintenance or repair

### Precautions during maintenance or repair

1. Always use the correct safety equipment (such as safety glasses, gloves, safety shoes, etc.).
2. Use only the correct tools for maintenance and repair work.
3. Use only genuine spare parts.
4. All maintenance work shall only be undertaken when the machine has cooled down.
5. A warning sign bearing a legend such as "Work in progress - do not start" shall be attached to the starting equipment.
6. Persons switching on remotely controlled machines shall take adequate precautions to ensure that there is no one checking or working on the machine. To this end, a suitable notice shall be affixed to the remote starting equipment.
7. Close the dryer air outlet valve before connecting or disconnecting a pipe.
8. Before removing any pressurized component, effectively isolate the machine from all sources of pressure and relieve the entire system of pressure.
9. Never use flammable solvents or carbon tetrachloride for cleaning parts. Take safety precautions against toxic vapors of cleaning liquids.
10. Scrupulously observe cleanliness during maintenance and repair. Keep dirt away by covering the parts and exposed openings with a clean cloth, paper or tape.
11. Never weld on, or in any way modify, pressure vessels.
12. Whenever there is an indication or any suspicion that an internal part of a machine is overheated, the machine shall be stopped. No inspection covers shall be opened before enough cooling time has elapsed. This is done to avoid the risk of spontaneous ignition of the oil vapor when air is admitted.
13. Never use a light source with open flame for inspecting the interior of a machine, pressure vessel, etc.
14. Make sure that no tools, loose parts or rags are left in or on the machine.
15. All regulating and safety devices shall be maintained with due care to ensure that they function properly. They may not be put out of operation.
16. Before clearing the machine for use after maintenance or overhaul, check that operating pressures, temperatures and time settings are correct. Check that all control and shut-down devices are fitted and that they function correctly.
17. Protect the motor, electrical and regulating components, etc. to prevent moisture from entering them, e.g. when steam-cleaning.

18. Make sure that all sound-damping material and vibration dampers, e.g. damping material on the bodywork, is in good condition. If damaged, replace with genuine material from the manufacturer to prevent the sound pressure level from increasing.
19. Never use caustic solvents which can damage materials of the air net, e.g. polycarbonate bowls.
20. **The following safety precautions are stressed when handling desiccant:**
  - Take precautions not to inhale desiccant dust.
  - Check that the working area is adequately ventilated; if required, use breathing protection.
  - Do not overfill the dryer when replacing desiccant.



Also consult following safety precautions: [Safety precautions during installation](#) and [Safety precautions during operation](#).  
 These precautions apply to machinery processing or consuming air or inert gas. Processing of any other gas requires additional safety precautions typical to the application which are not included herein.  
 Some precautions are general and cover several machine types and equipment; hence some statements may not apply to your machine.

## 1.6 Dismantling and disposal

### Dismantling

Once the end of life of the machine is reached, please follow next steps:

1. Stop the machine.
2. Check all safety precautions mentioned in the previous chapters to secure safe handling (e.g. LOTO, cool-down, depressurize, discharge, ...).
3. Separate the harmful from the safe components (e.g. drain oil from oil containing parts).
4. Refer to the disposal topic mentioned below.

### Disposal of electrical and electronic appliances (WEEE)

This equipment falls under the provisions of the European Directive 2012/19/EU on waste electrical and electronic appliances (WEEE) and may not be disposed as unsorted waste.



The equipment is labelled in accordance with the European Directive 2012/19/EU with the crossed-out wheeled bin symbol.

At the end of life-time of the electric and electronic equipment (EEE) it must be taken to separate collection.

For more information check with your local waste authority, customer center or distributor.

**Disposal of other used material**

Used filters or any other used material (e.g. filter bags, filter media, desiccant, lubricants, cleaning rags, machine parts, etc.) must be disposed of in an environmentally friendly and safe manner, and in line with the local recommendations and environmental legislation.

## 2 General description

### 2.1 General description

#### Introduction

The air dryers described in this book are heatless adsorption dryers, designed to remove humidity from compressed air for industrial applications.

The High Efficiency (+) version of the CD dryers is available in a version to reach a pressure dew point down to  $-20\text{ }^{\circ}\text{C}$  ( $-4\text{ }^{\circ}\text{F}$ ),  $-40\text{ }^{\circ}\text{C}$  ( $-40\text{ }^{\circ}\text{F}$ ) or  $-70\text{ }^{\circ}\text{C}$  ( $-100\text{ }^{\circ}\text{F}$ ) and is standard equipped with a DC1 electronic controller. An Elektronikon™ controller with graphical display, including a pressure dew point (PDP) sensor is available as option.

The dryers are designed for indoor use and at altitudes up to 2000 m (6560 ft).



*CD 90<sup>+</sup> with DC1 controller — General view*

#### Main parts

An overview of the main parts of the dryer is given in the image below:

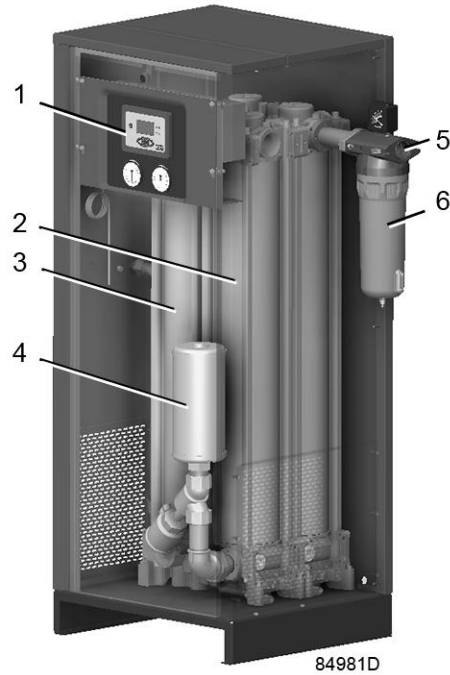

CD 90+ — Main parts

| Reference | Description    | Reference | Description |
|-----------|----------------|-----------|-------------|
| 1         | DC1 controller | 4         | Silencer    |
| 2         | Right tower    | 5         | Air outlet  |
| 3         | Left tower     | 6         | Dust filter |

## 2.2 Operation

### General

With its simple construction, the air dryer is both reliable and easy to service. A dryer module basically consists of two towers, containing the adsorption material or desiccant. The desiccant is a very porous grain material, able to adsorb large amounts of water vapor.

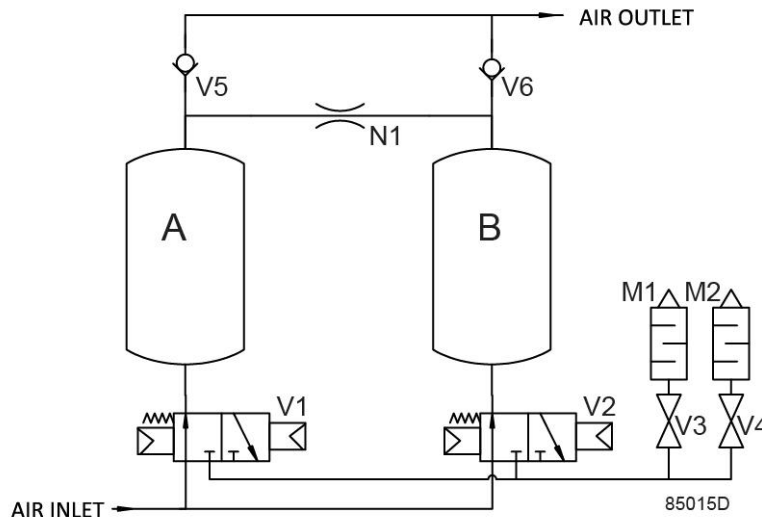

Flow diagram

| Reference  | Designation           | Reference | Designation           |
|------------|-----------------------|-----------|-----------------------|
| AIR INLET  | Air inlet             | V4        | Regeneration valve    |
| AIR OUTLET | Air outlet            | V5        | Left check valve      |
| A          | Left desiccant tower  | V6        | Right check valve     |
| B          | Right desiccant tower | M1        | Blow off silencer     |
| V1         | Left 3–2 valve        | M2        | Regeneration silencer |
| V2         | Right 3–2 valve       | N1        | Nozzle                |
| V3         | Blow off valve        |           |                       |

Depending on dryer size, the dryer may consist of a single dryer module (see flow diagram) or a combination of several dryer modules in parallel.

### Operation principle

The operation cycle of the dryer is repetitive and is controlled by a factory set timer in the controller or by the pressure dew point (PDP) sensor, which is optionally available. While the desiccant in one tower dries the compressed air, the desiccant in the second tower is being regenerated. Regeneration of the desiccant is achieved by means of purge air from the drying tower.

The compressed air entering the dryer is led to one of the towers by means of one of the two 3–2 valves. The position of the 3–2 valves is controlled by the solenoid valves. As the air flows upwards through the tower, the desiccant adsorbs the water vapor and the compressed air is dried. The dried air leaves the dryer via the outlet check valve.

A small portion of the dried air passes a nozzle, expands to atmospheric pressure and flows downwards through the other tower, regenerating (drying) the desiccant. A nozzle for operation of the dryer at 7 bar is installed as standard. Alternative nozzles for use at different operating pressures may be delivered with the units. Contact your supplier. The regeneration air is released via the corresponding solenoid valve and the silencer. The solenoid valves are controlled by the timer.

After a preset period (or when triggered by the PDP sensor) the function of the towers is reversed. The fully regenerated tower will now dry the air, while the desiccant in the other tower will be regenerated.

By default, the regeneration timer will restart from the beginning of the cycle in case of a power failure during operation or in case the dryer was switched off.

The working sequence of the controller is as follows:

| Status | Left tower                          | Right tower                         | V1 | V2 | V3 | V4 |
|--------|-------------------------------------|-------------------------------------|----|----|----|----|
| 0      | Stopped                             | Stopped                             | 0  | 0  | 0  | 0  |
| 1      | Adsorbing                           | Adsorbing                           | 0  | 0  | 0  | 0  |
| 2      | Shifting                            | Adsorbing                           | 1  | 0  | 0  | 0  |
| 3      | Depressurizing                      | Adsorbing                           | 1  | 0  | 1  | 0  |
| 4      | Regenerating                        | Adsorbing                           | 1  | 0  | 1  | 1  |
| 5      | Equalizing                          | Adsorbing                           | 1  | 0  | 0  | 0  |
| 6      | Freeze (compressor synchronization) | Adsorbing                           | 1  | 0  | 0  | 0  |
| 7      | Standby                             | Adsorbing                           | 1  | 0  | 0  | 0  |
| 8      | Adsorbing                           | Adsorbing                           | 0  | 0  | 0  | 0  |
| 9      | Adsorbing                           | Shifting                            | 0  | 1  | 0  | 0  |
| 10     | Adsorbing                           | Depressurizing                      | 0  | 1  | 1  | 0  |
| 11     | Adsorbing                           | Regenerating                        | 0  | 1  | 1  | 1  |
| 12     | Adsorbing                           | Equalizing                          | 0  | 1  | 0  | 0  |
| 13     | Adsorbing                           | Freeze (compressor synchronization) | 0  | 1  | 0  | 0  |
| 14     | Adsorbing                           | Standby                             | 0  | 1  | 0  | 0  |

When the ON/OFF push-button is pressed during operation, the controller jumps automatically to status 5 or 12 (equalization phase). After that, the Stop status (0) will be reached. The following start command will restart the sequence from the state 2 or 9. The same happens when the power is switched off.

On dryers with an Elektronikon™ Graphic controller, the function PDP Extended Cycle can be activated. See section [Modifying Settings](#). When this function is activated, the regeneration air flow stops when the PDP is reached.

### 3 Electric diagram

The complete electric diagram can be found in the electrical cabinet and in your technical documentation.

| Drawing number | Controller type    |
|----------------|--------------------|
| 9827 2939 00   | Graphic controller |

## 4 DC1 controller

### 4.1 Control panel

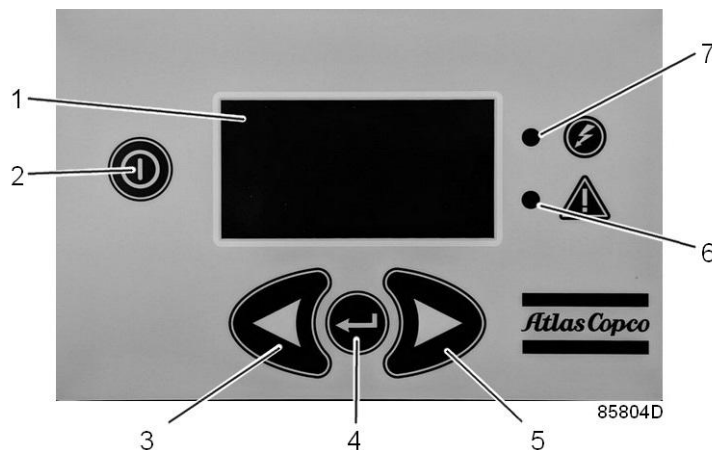

|   |               |
|---|---------------|
| 1 | Display       |
| 2 | ON/OFF button |
| 3 | LEFT button   |
| 4 | ENTER button  |
| 5 | RIGHT button  |
| 6 | Alarm LED     |
| 7 | Power On LED  |

#### Button functions

Press any button to light up the display.

| Button  | Normal operation       | Alarm status | Selection menu                        | Alarms browser                         | Parameters editing                                     | Counters and service menu |
|---|------------------------|--------------|---------------------------------------|--|--|---------------------------|
| ON/OFF  | Starts/stops the dryer |              |                                       |  |  |                           |
| LEFT  | No action              | No action    | Moves the cursor upwards cyclically   | Displays the previous alarm cyclically | — Selects the parameter<br>— Decrements the data value | No action                 |
| With the PDP option available, you can press the left or right button to show a graph of the PDP. |                        |              |                                       |  |  |                           |
| RIGHT   | No action              | No action    | Moves the cursor downwards cyclically | Displays the next alarm cyclically     | — Selects the parameter<br>— Increments the data value | No action                 |
| With the PDP option available, you can press the left or right button to show a graph of the PDP. |                        |              |                                       |  |  |                           |

| Button | Normal operation            | Alarm status  | Selection menu                            | Alarms browser   | Parameters editing  | Counters and service menu     |
|--------|-----------------------------|---|---|--|---|-------------------------------|
| ENTER  | Displays the selection menu | Cancels the displayed alarm for one minute (alarm acknowledgment) | Selects the pointed menu and activates it | — Returns to the selection menu<br>— Cancels the service alarm, if pressed for 5 s | — Starts the parameter editing<br>— Selects the numerical data digits<br>— Confirms the modified value<br>— Pressed for at least 2 s, returns to the selection menu | Returns to the selection menu |

### LED functions



| LED      | Color        | Description                                |
|----------|--------------|--|
| Power ON | Green        | The controller is turned on.               |
| Alarm    | Blinking red | The controller is in alarm condition.      |
|          | Fixed red    | The controller needs technical assistance. |

## 4.2 Main screen

During normal operation the following image is displayed:



- In the upper right area, the current working phase countdown and the measured dew point are displayed.  
When the pressure dew point (PDP) sensor is not enabled, the dew point is not displayed. When the PDP sensor is enabled but either not connected or defective, no dew point value is displayed (four dashes substitute the measure).
- In the lower area, the current working phase of each vessel is displayed.
- In the upper left area of the screen, an animated icon is present:

| Icon  | Description   |
|---|---|
|  | Rotating arrow<br>Displayed when the dryer is in its working phases.          |
|  | Stationary vertical bars<br>Displayed when the dryer is in the FREEZE status. |
|  | Stationary square<br>Displayed when the dryer is stopped.                     |

The various working phases are:

| Phase             | Text displayed on screen | Translation |
|-------------------|--------------------------|-------------|
| Stop              | STOPPED                  | STOPPED     |
| Shifting          | SHIFTING                 | SHIFTING    |
| Adsorbing         | ADSORBING                | ADSORBING   |
| Pressure relief   | DEPRESS                  | DEPRESS     |
| Regeneration      | REGENERAT                | REGENERAT   |
| Pressure equalize | EQUALIZE                 | EQUALIZE    |
| Freeze            | FREEZE                   | FREEZE      |
| Standby           | STANDBY                  | STANDBY     |
| Blowing off       | BLOW OFF                 | BLOW OFF    |

### 4.3 Selection Menu

When you press ENTER in the normal operation main screen (not during alarm!), you will see the following selection menu:



Press LEFT or RIGHT to navigate to the required menu item and press ENTER to select.

|   | Selection | Translation | Description              |
|---|-----------|-------------|--------------------------|
| 1 | Alarms    | Alarms      | Alarms browser           |
| 2 | Settings  | Settings    | Parameters list          |
| 3 | Counters  | Counters    | Counters status          |
| 4 | Service   | Service     | Service status           |
| 5 | Exit      | Exit        | Back to the main display |

Select item 5 (Exit) to return to the main screen or wait approximately 30 seconds.

## 4.4 Alarm screen

When there is an alarm, you will see the following image on your screen:



When one or more alarms are active, the alarm screen overrides the main screen.

In the upper right area, the current alarm number and the total active alarms number are displayed.

In the lower area, the current alarm description is displayed.

If more than one alarm is active, the fault messages are shown every 2 seconds.

Pressing ENTER acknowledges the alarm currently being displayed.

If all the alarms have been cleared, you will return automatically to the main screen.

After one minute, if the acknowledged alarm is still active, the alarm display is shown again.

The icon in the upper left area blinks.

Possible alarm causes:

| Module involved                         | Cause   | Message on the display  | How to clear the alarm  | Alarm LED status |
|---|---|-------------------------|---|------------------|
| PDP (English:Pressure Dew Point) sensor | PDP above or equal to the minimum value of the PDP range      | PDP is not connected    | Verify if the PDP sensor is correctly connected and if it is not damaged. | Blinking         |
|   | PDP lower than or equal to the minimum value of the PDP range | PDP measure is wrong    | Verify if the PDP sensor is correctly connected and if it is not damaged. | Blinking         |
|   | PDP sensor supply voltage < 20 V                              | PDP supply is in fault  | Verify if the sensor supply voltage is correct.                           | Blinking         |
|   | PDP more than 10 °C (18 °F) above the desired setpoint        | PDP meas > the setpoint | The alarm is automatically cleared when the desired dew point is reached. | Blinking         |

| Module involved | Cause  | Message on the display                          | How to clear the alarm  | Alarm LED status |
|-----------------|--|---|---|------------------|
| Service         | Running hours > programmed service hours A, B or C | Running hours > service hours X (X = A, B or C) | Perform the requested maintenance (A, B or C). Next, enter the Alarm menu, select Service Alarm, press the ENTER button and keep it pressed during minimum 5 s. | Blinking         |
| 24 V supply     | Supply voltage < 18 V                              | 24 V supply is in fault                         | Contact your supplier   | Blinking         |
| Controller      | Controller hardware fault                          | Internal error                                  | Reset all settings to the default value. Switch off the controller and switch it on again. Call your supplier if the fault persists.                            | Lit continuously |

When an alarm is active, relay K01 is closed (relay X15, contacts 9 en 10) . When all the alarms are cleared, K01 is open.

Acknowledgement of the alarms does not affect the status of K01 or the status of the red LED.

See section [Electric diagram](#).

## 4.5 Editing parameters

During parameters editing (see menu item Settings in [Selection menu](#) ), you will see a similar image on your screen:



In the upper right area, the current parameter number and the total modifiable parameters number are visualized.

In the lower area, the current parameter description and value are displayed.

**Only the unprotected parameters** can be displayed and modified! Example of settings that are accessible to the end user are Automatic restart after voltage failure (ARAVF), language and the display time-out.

Pressing ENTER for at least 2 seconds ends the editing procedure. The display will return to the selection menu.

## Editor button functions

| Button | Function  |
|--------|---|
| LEFT   | <ul style="list-style-type: none"> <li>• Selects the previous parameter</li> <li>• Decrements the value</li> </ul>  |
| RIGHT  | <ul style="list-style-type: none"> <li>• Selects the next parameter</li> <li>• Increments the value</li> </ul>  |
| ENTER  | <ul style="list-style-type: none"> <li>• Starts the parameter editing</li> <li>• Selects the numerical data digits</li> <li>• Confirms the modified value</li> <li>• <b>Pressing ENTER for at least 2 seconds ends the editing procedure. The display will return to the selection menu.</b></li> </ul> |

## How to modify a parameter

| Step | Button involved | Action  |
|------|-----------------|---|
| 1    | RIGHT or LEFT   | To select the parameter to be modified  |
| 2    | ENTER           | Starts the modification procedure <ul style="list-style-type: none"> <li>• If the parameters is a selection value (e.g. a language) or a boolean value (On or Off), go to step 3</li> <li>• If the parameters is a numerical value, press the ENTER button repeatedly as required.</li> </ul>   |
| 3    | RIGHT or LEFT   | Modifies the selected parameter <ul style="list-style-type: none"> <li>• If the parameter is a selection value (e.g. a language), pressing RIGHT increments and pressing LEFT decrements the selection within the allowed range.</li> <li>• If the parameter is a boolean value (On or Off), RIGHT forces the data to ON, LEFT to OFF.</li> <li>• If the parameters is a numerical value, RIGHT increments and LEFT decrements the selected digit.</li> </ul> |
| 4    | ENTER           | <ul style="list-style-type: none"> <li>• For numerical data, ENTER moves the cursor to the upper digit (see step 2). If the digit is the last one, ENTER closes the editing phase</li> <li>• For selection or Boolean values, ENTER closes the editing phase.</li> </ul>  |

## Modifiable parameters

Following parameters can be modified without password:

| Parameter number | Parameter name                                 | Description   | Default value | Allowed range  |
|------------------|--|---|---------------|--|
| 1                | ARAVF(Automatic restart after voltage failure) | Selects if the controller will restart automatically or not in case of power failure. | Off           | On or Off  |
| 2                | Language                                       | Selects the language of the displayed messages.                                       | English       | English, French, Spanish, Italian, Portuguese, German, Russian |
| 3                | Display timeout                                |   | 5 min         | 1 — 999 min  |

| Parameter number | Parameter name    | Description  | Default value  | Allowed range   |
|------------------|-------------------|--|--|---|
| 4                | PDP control       | On: The dryer tries to follow the set point.<br>Off: only display the PDP. The dryer will run at the lowest possible dewpoint. | Off  | On or Off   |
| 5                | Dewpoint setpoint | Fixes the target for the PDP   | Based on the model of dryer: <ul style="list-style-type: none"> <li>• -20 °C (-4 °F)</li> <li>• -40 °C (-40 °F)</li> <li>• -70 °C (-100 °F)</li> </ul> | Maximum value: -10 °C (+14 °F)<br>Minimum value: <ul style="list-style-type: none"> <li>• -20 °C (-4 °F)</li> <li>• -40 °C (-40 °F)</li> <li>• -70 °C (-100 °F)</li> </ul> based on the model of dryer. |
| 6                | PDP temp in °F    | Selects the temperature unit   | Off  | On or Off   |

**All other parameters are protected by a password and need no modification.**

### PDP Sensor retrofit

PDP sensor retrofit kit number: 8092 2617 79

Press the Enter button for at least 2 seconds to return to the selection menu.

For controllers with software version 1.02.x and higher, use password: **4321**. Please note that the password has to be entered from the right to the left.

To edit the PDP parameters:

1. Go to parameter number 8: Enable PDP sensor  
Set parameter: 'ON'
2. Go to parameter number 4: PDP control  
Choose preferred behaviour.
3. Go to parameter number 5  
Modify and confirm preferred setpoint.

For controllers using software version 1.01.x, contact your supplier.

### Service

After servicing, press ENTER for at least 5 seconds to confirm that the service has been executed.

## 5 Graphic controller

### 5.1 General

#### Controller

A controller with a graphical screen is available as option for High Efficiency (+) versions, replacing the basic controller.



*Elektronikon™ Graphic controller*

#### General description

**The controller automatically controls and protects the dryer, i.e.:**

- Keeping the pressure dew point stable
- Monitoring pressure, temperature, and digital switches to ensure safe operation as well as stopping the dryer whenever necessary
- Restarting the dryer when required

**In order to control the dryer and to read and modify programmable parameters, the regulator has a control panel provided with:**

- LEDs indicating the status of the dryer
- A display indicating the operating conditions or a fault
- Keys to control the dryer and to access the data collected by the regulator
- Buttons to manually start and stop the dryer

#### Automatic restart after voltage failure (ARAVF)

The regulator has a built-in function to automatically restart the dryer if the voltage is restored after voltage failure.

If the function is activated and if the regulator was in the automatic operation mode, the dryer will automatically restart if the supply voltage to the module is restored within a programmed time period.



The power recovery time (the period within which the voltage must be restored to have an automatic restart) can be set between 15 and 3600 seconds or to 'Infinite'. If the power recovery time is set to 'Infinite', the dryer will always restart after a voltage failure, no matter how long it takes to restore the voltage. See section [Modifying Settings](#). A restart delay can also be programmed, allowing for example the dryer and the compressors to be restarted one after the other.

**General remark**

The information in this chapter is to be considered as a principal explanation. Some specific elements may not be applicable to each dryer.

**5.2 Control panel**

**Function keys of the controller**

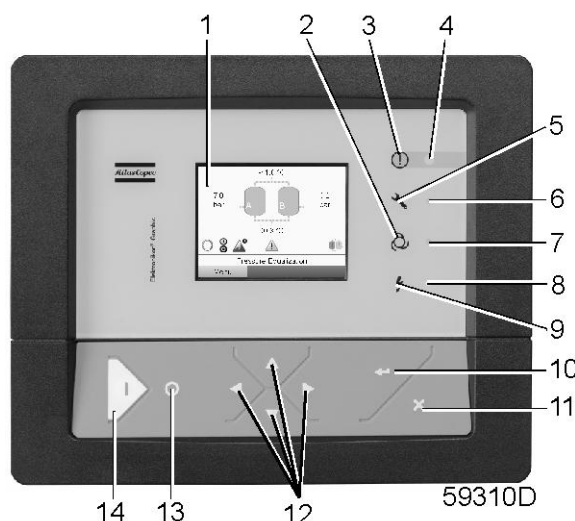











**Parts and functions**

| Reference | Designation             | Function  |
|-----------|-------------------------|---|
| 1         | Display                 | Shows the dryer operating condition and a number of icons to navigate through the menu. |
| 2         | Pictograph              | Automatic operation   |
| 3         | Pictograph              | General alarm   |
| 4         | General alarm LED       | Flashes if a shut-down warning condition exists.  |
| 5         | Pictograph              | Service   |
| 6         | Service LED             | Lights up if service is needed  |
| 7         | Automatic operation LED | Indicates that the regulator is automatically controlling the dryer.                    |
| 8         | Voltage on LED          | Indicates that the voltage is switched on.  |
| 9         | Pictograph              | Voltage on  |
| 10        | Enter key               | Key to activate the selected menu or to modify the selected parameter.                  |

| Reference | Designation  | Function  |
|-----------|--------------|---|
| 11        | Escape key   | To go to the previous screen or to end the current action                                 |
| 12        | Scroll keys  | Keys to scroll through the menu.  |
| 13        | Stop button  | Button to stop the dryer. LED (7) goes out.   |
| 14        | Start button | Button to start the dryer. LED (7) lights up indicating that the controller is operative. |





## 5.3 Icons used

### Status icons









| Name                                    | Icon   | Description  |
|---|--|--|
| Stopped/Running                         |  57786F   | When the dryer is stopped, the icon stands still. When the dryer is running, the icon is rotating. |
| Machine control mode                    |  57790F   | Local start/stop   |
|   |  57791F | Remote start/stop  |
|   |  57792F | Network control  |
| Automatic restart after voltage failure |  57793F | Automatic restart after voltage failure is active  |
| Week timer                              |  57794F | Week timer is active   |
|   |  57796F | Shutdown   |
|   |  57797F | Warning  |
| Service                                 |  57798F | Service required   |
| Main screen                             |  59162F | Change main screen   |

|  |   |            |
|--|---|------------|
|  | <br>82196F | Main chart |
|--|---|------------|













**Input icons**

| Icon  | Description        |
|---|--------------------|
| <br>57796F | Pressure           |
| <br>57800F | Temperature        |
| <br>57801F | Digital input      |
| <br>57802F | Special protection |



**System icons**

| Icon  | Description              |
|---|--------------------------|
| <br>57804F | Dryer                    |
| <br>57805F | Fan                      |
| <br>57806F | Frequency converter      |
| <br>57807F | Drain                    |
| <br>57808F | Filter                   |
| <br>57809F | Motor                    |
| <br>57810F | Failure expansion module |
| <br>57792F | Network problem          |
| <br>57812F | General alarm            |

## Menu icons

| Icon   | Description                  |
|--|------------------------------|
|  57813F   | Inputs                       |
|  57814F   | Outputs                      |
|  57812F   | Alarms (Warnings, shutdowns) |
|  57815F   | Counters                     |
|  58499D   | Test                         |
|  57817F   | Settings                     |
|  57798F   | Service                      |
|  57818F | Event history (saved data)   |
|  57819F | Access key/User password     |
|  57792F | Network                      |
|  57820F | Set point                    |
|  57867F | Info                         |
|  59807D | General settings             |

## Navigation arrows

| Icon   | Description |
|--|-------------|
|  57821F | Up          |
|  57822F | Down        |

## 5.4 Main screen

### Control panel

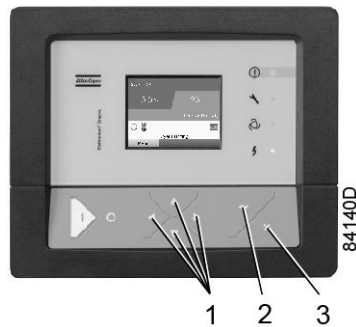

|     |             |
|-----|-------------|
| (1) | Scroll keys |
| (2) | Enter key   |
| (3) | Escape key  |

### Function

The main screen shows the status of the dryer operation and is the gateway to all functions implemented in the controller.

The main screen is shown automatically when the power is switched on and one of the keys is pushed. It is switched off automatically after a few minutes when no keys are pushed.

Six different main views can be chosen:

1. Dryer animation
2. Two value lines
3. Four value lines
4. Chart (High Resolution)
5. Chart (Medium Resolution)
6. Chart (Low Resolution)

**Dryer animation, two and four value views**

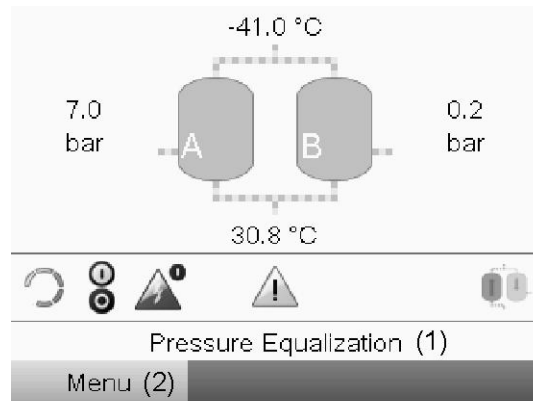

59307D

*Dryer animation*

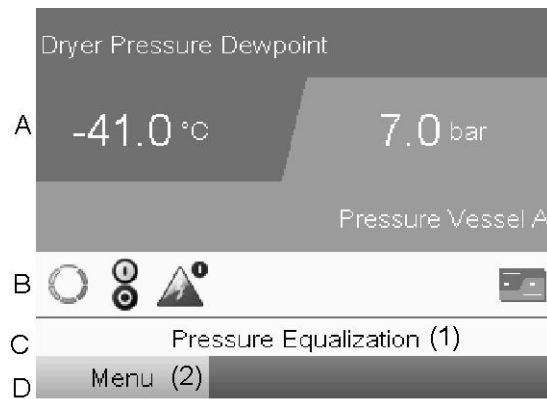

59312D

*Two value lines*

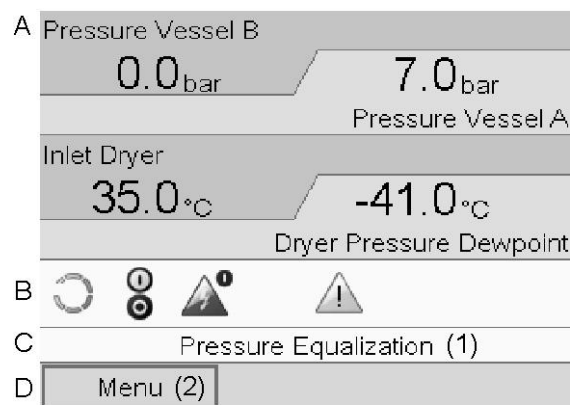

58535D

*Four value lines*

## Text on figures

|     |                       |
|-----|-----------------------|
| (1) | Pressure equalization |
| (2) | Menu                  |

- **Section A** shows information regarding the dryer operation (e.g. the Pressure in vessels A and B, the Dryer Pressure Dewpoint, the Dryer Inlet temperature).
- **Section B** shows Status icons. Following icon types are shown in this field:
  - Fixed icons  
These icons are always shown in the main screen (e.g. Dryer stopped or running, Dryer status).
  - Optional icons  
These icons are only shown if their corresponding function is activated (e.g. week timer, automatic restart after voltage failure, etc.).
  - Pop up icons  
These icons pop up if an abnormal condition occurs (warnings, shutdowns, service,...).  
To call up more information about the icons shown, select the icon using the scroll keys and press the enter key.
- **Section C** is called the Status bar.  
This bar shows the text that corresponds to the selected icon. When the menu button is selected, this text shows the operational state of the dryer.
- **Section D** shows the Action buttons. These buttons are used:
  - to call-up or program settings.
  - to reset a service message.
  - to have access to all data collected by the controller.
 The function of the buttons depends on the displayed menu. The most common functions are:

| Designation | Function                        |
|-------------|---------------------------------|
| Menu        | To go to the menu               |
| Modify      | To modify programmable settings |
| Reset       | To reset a timer or message     |

To activate an action button, highlight the button by using the Scroll keys and press the Enter key.

To go back to the previous menu, press the Escape key.

**Chart views**



59166D

When Chart (High Resolution) is selected, the value of a parameter (in the example, the pressure is selected, but it could have been the PDP as well) is shown per minute. The parameter is selected in the Inputs menu. Each point in the chart is 1 second. The screen shows 4 minutes.

The switch button (icon) for selecting other screens is changed into a small chart and is highlighted (active).

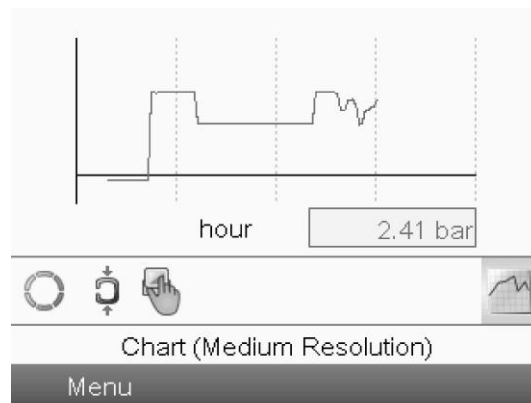

59167D

When the Chart (Medium Resolution) is selected, a chart showing the parameter per hour is shown on the main screen. Each point is the average of 1 minute. The screen shows 4 hours.

The switch button (icon) for selecting other screens is changed into a small chart and is highlighted (active).

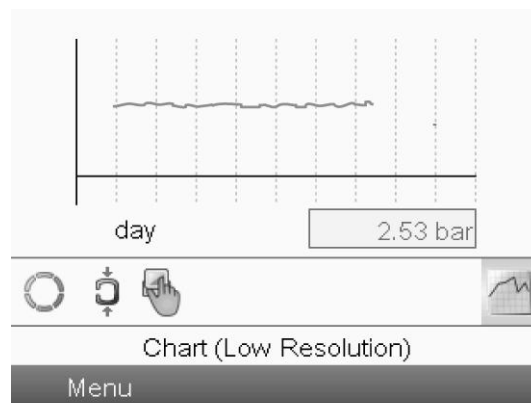

59168D

When the Chart (Low Resolution) is selected, a chart showing the parameter per day is shown on the main screen. Each point is the average of 1 hour. The screen shows 10 days.

The switch button (icon) for selecting other screens is changed into a small chart and is highlighted (active).

## 5.5 Calling up menus

When the voltage is switched on, the main screen is shown automatically (see section [Main screen](#)):

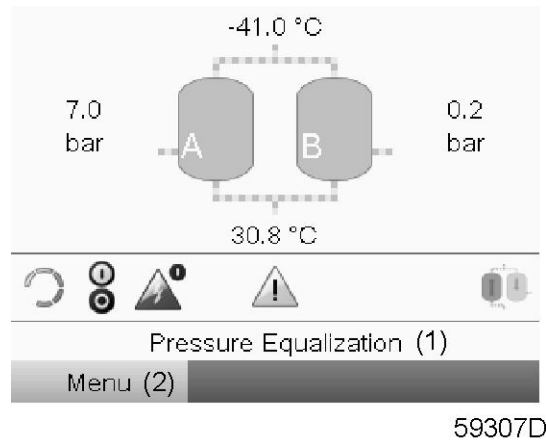

|     |                       |
|-----|-----------------------|
| (1) | Pressure equalization |
| (2) | Menu                  |

- To go to the Menu screen, highlight the Menu button (2), using the Scroll keys.
- Press the Enter key to select the menu. Following screen appears:

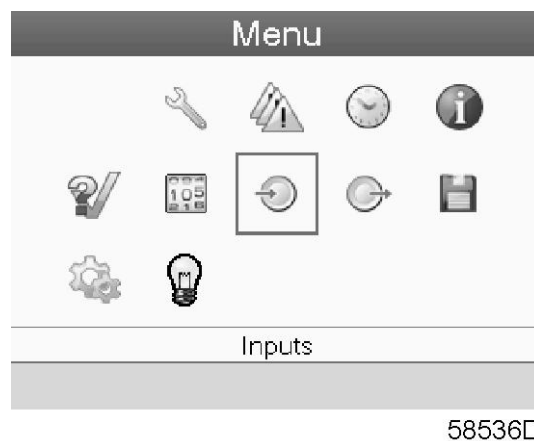

- The screen shows a number of icons. Each icon indicates a menu item. By default, the Inputs icon is selected. The status bar shows the name of the menu that corresponds with the selected icon.
- Use the Scroll keys to select an icon.
- Press the Enter key (2) to open the menu or press the Escape key (3) to return to the Main screen.

## 5.6 Inputs menu

### Menu icon, Inputs



### Function

To call up information regarding the actually measured data and the status of some inputs such as the Vessel Pressure.

### Procedure

Starting from the main screen (see [Main screen](#)),

- Move the cursor to the action button Menu and press the Enter key. Following screen appears:

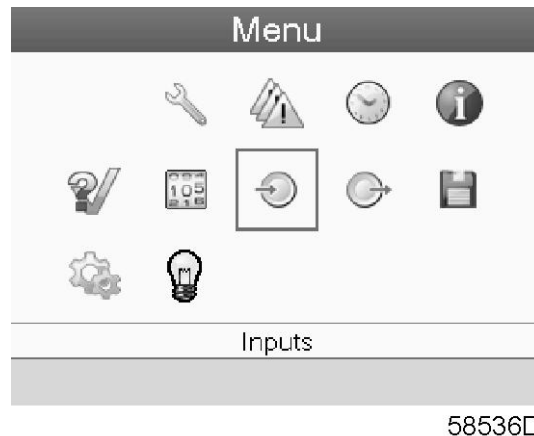

58536D

- Press the Enter key. A screen similar to the one below appears:

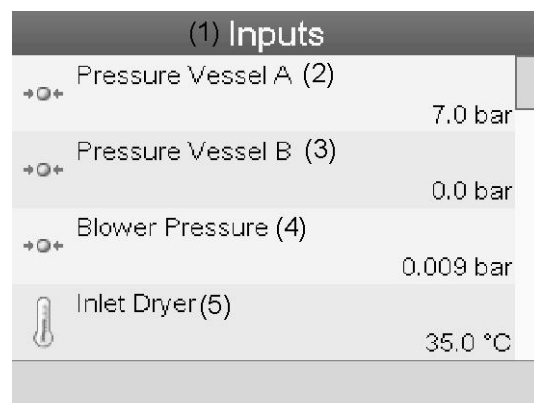

58538D

Text on figure

|     |                   |
|-----|-------------------|
| (1) | Inputs            |
| (2) | Pressure vessel A |
| (3) | Pressure vessel B |
| (4) | Blower pressure   |
| (5) | Inlet dryer       |

- The screen shows the first items of a list of all inputs with their corresponding icons and readings. Use the scroll button to see the other items in the list.
- If an input is in warning or shutdown, the original icon is replaced by the warning or shutdown icon respectively.

## 5.7 Outputs menu

### Menu icon, Outputs



### Function

To call up information regarding the actual status of some outputs such as the Dryer motor, PDP alarm, General shut-down, etc.

### Procedure

Starting from the Main screen (see [Main screen](#)),

- Move the cursor to the action button Menu and press the Enter key. Following screen appears:

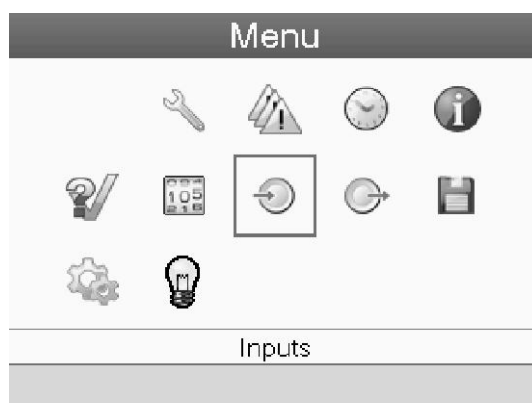

58536D

- Move the cursor to the Outputs icon using the Scroll keys.
- Press the Enter key. A screen similar to the one below appears:

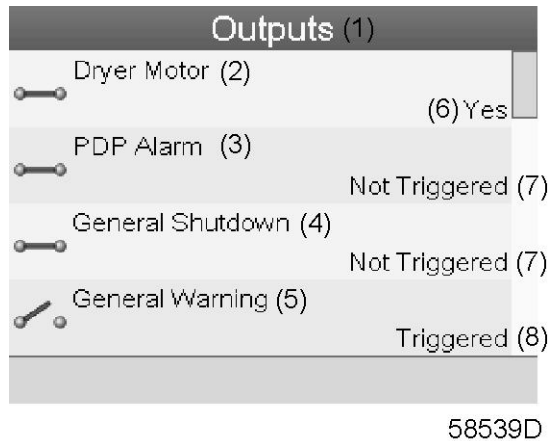

Text on figure

|     |  |
|-----|--|
| (1) | Outputs                                    |
| (2) | Dryer motor (means the dryer is operating) |
| (3) | PDP alarm                                  |
| (4) | General shut-down                          |
| (5) | General warning                            |
| (6) | Yes  |
| (7) | Not triggered                              |
| (8) | Triggered                                  |

- The screen shows the first items of a list of all outputs with their corresponding icons and readings. Use the scroll button to see the other items in the list.

## 5.8 Counters

### Menu icon, Counters



### Function

To call up:

- The running hours
- The number of dryer starts
- The number of hours that the regulator has been powered
- The operational state timers

### Procedure

Starting from the Main screen (see [Main screen](#)),

- Move the cursor to the action button Menu and press the Enter key. Following screen appears:

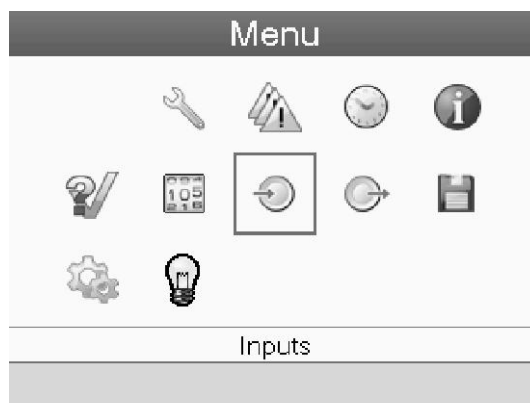

58536D

- Using the Scroll keys, move the cursor to the Counters icon (see above, section Menu icon).
- Press the Enter key. Following screen appears:

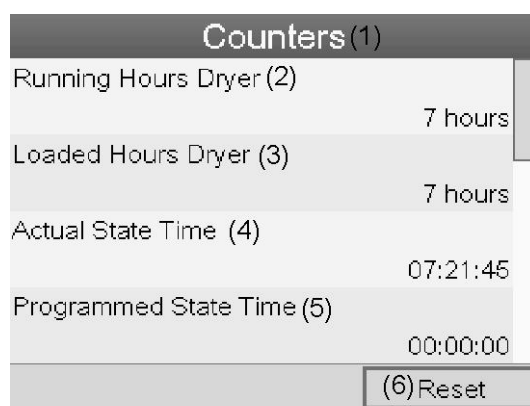

58540D

Text on figure

|     |                       |
|-----|-----------------------|
| (1) | Counters              |
| (2) | Running hours dryer   |
| (3) | Loaded hours dryer    |
| (4) | Actual state time     |
| (5) | Programmed state time |
| (6) | Reset                 |

The screen shows a list of all counters with their actual readings. A number of counters keep track of the state of the dryer:

- **Running hours:** counts the operation hours of the dryer.
- **Loaded hours:** the same as running hours, but shows to which time interval the energy counters refer to; this counter is also reset when the energy counters are reset.
- **Actual state time:** shows how long the dryer's current state has been active.
- **Programmed state time:** shows how long (at most) the current state should be active.
- **Actual half cycle time:** shows how long the adsorbing vessel has been adsorbing (since last vessel shift).
- **Programmed half cycle time:** shows how long the half cycle should take; minimum value if PDP control is not active, maximum value if PDP is active.
- **Regeneration cycles vessel A:** integer that counts how many cycles vessel A has performed.

- **Regeneration cycles vessel B:** integer that counts how many cycles vessel B has performed.
- **Standby time:** shows how long the dryer has been in standby mode since the last reset of the energy counters. This counter will not be reset when the standby state has ended and a vessel switch is performed. The next time the dryer is in the standby state, it resumes at the previous value. The counter is automatically reset when the energy counters are reset.
- **Energy saving PDP sensor:** shows how much energy is saved (in %) by having the PDP sensor since the energy counters have been reset, so it equals  $\text{StandbyTime} / \text{LoadedTime}$ .
- **Average heating power:** shows the 24/24h average of heating power consumed since the last reset of the energy counters. This timer equals the  $(\text{Heater Contactor Time} \times \text{Heater Power}) / (\text{Loaded Time})$ . The Heater Contactor Time is an internal timer and can not be called up on the screen. The Heater Contactor Time is reset when the energy counters are reset.
- **Module hours:** shows how long the controller has been active. This timer can not be reset, not even when downloading new controller software.

## 5.9 Event history menu

### Menu icon, Event History



### Function

To call up the last shutdown and last emergency stop data.

### Procedure

Starting from the Main screen (see [Main screen](#)),

- Move the cursor to the action button Menu and press the Enter key. Following screen appears:

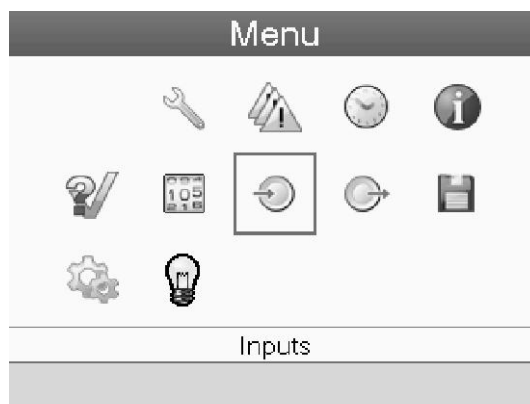

58536D

- Using the Scroll keys, move the cursor to the Event History icon (see above, section Menu icon).
- The list of last shutdown and emergency stop cases is shown.

- Scroll through the items to select the desired shutdown or emergency stop event.
- Press the Enter key to find the date, time and other data reflecting the status of the dryer when that shutdown or emergency stop occurred.

## 5.10 Test menu

### Menu icon, Test



### Function

- To depressurize the vessels and to test the output contacts.



- The vessels can only be depressurized when the dryer is stopped (off state).
- The test procedure will be stopped as soon as another menu is selected on the regulator.

### Procedure

Starting from the Main screen (see [Main screen](#)):

- Move the cursor to the action button Menu and press the enter key (2); following screen appears:

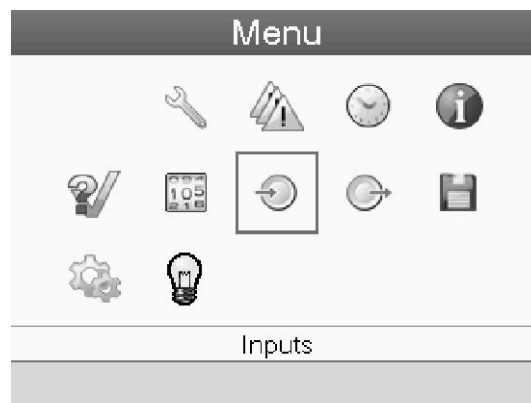

58536D

- Using the scroll keys (1), move the cursor to the test icon (see above, section Menu icon).
- Press the Enter key (2). Following screen appears:

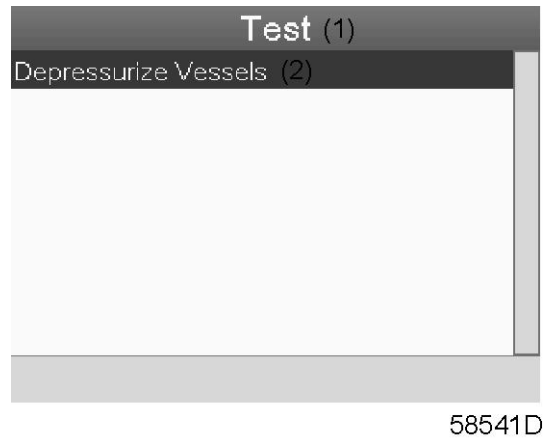

Text on figure

|     |                      |
|-----|----------------------|
| (1) | Test                 |
| (2) | Depressurize vessels |

- A red selection bar is covering the item Depressurize vessels. Press the Enter key to depressurize the vessels.

## 5.11 Service menu

Menu icon, Service



### Function

- To reset the service plans which are carried out.
- To check when the next service plans are to be carried out.
- To find out which service plans were carried out in the past.
- To modify the programmed service intervals.

### Procedure

Starting from the Main screen (see [Main screen](#)),

- Move the cursor to the action button Menu and press the Enter key. Following screen appears:



58536D

- Using the Scroll keys, move the cursor to the Service icon (see above, section Menu icon).
- Press the Enter key. Following screen appears:

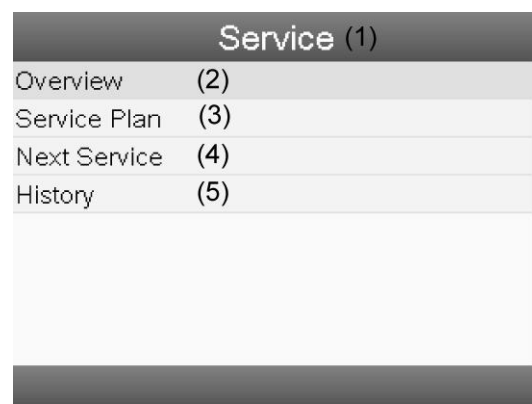

57847F\_1

Text on figure

|     |              |
|-----|--------------|
| (1) | Service      |
| (2) | Overview     |
| (3) | Service plan |
| (4) | Next service |
| (5) | History      |

- Scroll through the items to select the desired item and press the Enter key to see the details as explained below.

**Overview**



58542D

Text on figure

|     |                        |
|-----|------------------------|
| (1) | Overview               |
| (2) | Running Hours (green)  |
| (3) | Real Time hours (blue) |

Example for service level (A):

The figures at the left are the programmed service intervals. For Service interval A, the programmed number of running hours is 4000 hours (upper row, green) and the programmed number of real time hours is 4380 hours, which corresponds to six months (second row, blue). This means that the controller will launch a service warning when either 4000 running hours or 4380 real hours are reached, whichever comes first. Note that the real time hours counter keeps counting, also when the controller is not powered.

The figures within the bars are the number of hours to go till the next service intervention. In the example above, the dryer was just started up, which means it still has 4000 running hours or 4337 hours to go before the next Service intervention.

**Service plans**

A number of service operations are grouped (called Level A, Level B, etc...). Each level stands for a number of service actions to be carried out at the time intervals programmed in the controller.

When a service plan interval is reached, a message will appear on the screen.

After carrying out the service actions related to the indicated levels, the timers must be reset.

From the Service menu above, select Service plan (3) and press Enter. Following screen appears:

| Service Plan (1) |                   |               |
|------------------|-------------------|---------------|
| (2) Level        | (3) Running Hours | (4) Real Time |
| A                | 4000              | 4380          |
| B                | 8000              | 8760          |
| C                | 40000             | 43800         |
| D                |                   |               |
| E                |                   |               |

58543D

Text on figure

|     |               |
|-----|---------------|
| (1) | Service plan  |
| (2) | Level         |
| (3) | Running hours |
| (4) | Real time     |

**Next Service**

| Next Service (1) |                   |
|------------------|-------------------|
| (2) Level        | (3) Running Hours |
|                  | (4) Actual<br>8   |
| A                | 4000              |

58544D

Text on figure

|     |               |
|-----|---------------|
| (1) | Next service  |
| (2) | Level         |
| (3) | Running hours |
| (4) | Actual        |

In the example above, the A Service level is programmed at 4000 running hours, of which 8 hours have passed.

**History**

The History screen shows a list of all service actions done in the past, sorted by date. The date at the top is the most recent service action. To see the details of a completed service action (e.g.

Service level, Running hours or Real time hours), use the Scroll keys to select the desired action and press the Enter key.

## 5.12 Protections menu

### Menu icon, Protections



### Function

To call-up the protections.

|  |  |
|--|--|
|  | <p>Before resetting a warning or shut down message, always remedy the problem. Frequently resetting these messages without remedying may damage the dryer.</p> |
|--|--|

### Procedure

Starting from the Main screen (see [Main screen](#)):

- Move the cursor to the action button Menu and press the enter key (2). Following screen appears:

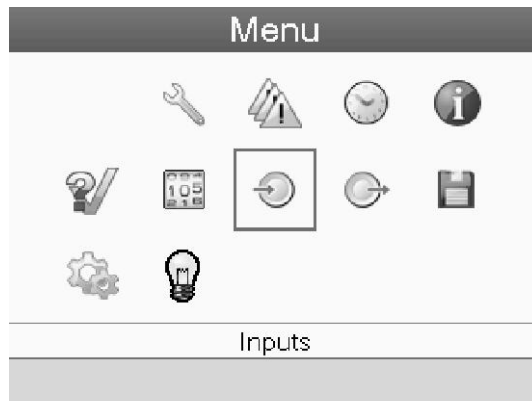

58536D

- Using the scroll keys (1), move the cursor to the protections icon (see above, section Menu icon).
- Press the enter key (2). Following screen appears:

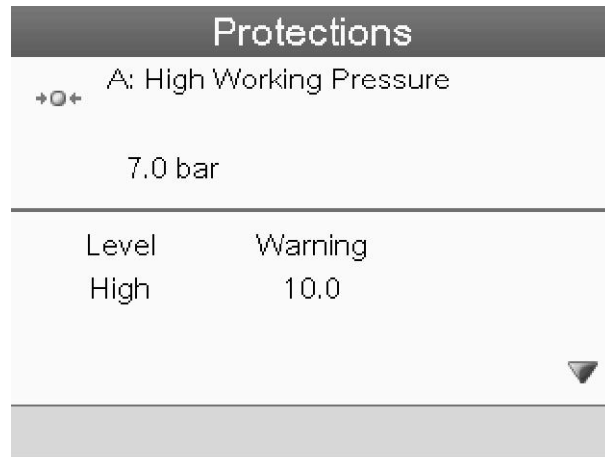

58545D

- The screen shows a list of all shutdown and shutdown warning settings and the actual reading. Active alarms are highlighted in yellow. In case of a shutdown, the protection can be reset after remedying.

## 5.13 Week timer menu

### Menu icon, Week timer



### Function

- To program time based start/stop commands for the dryer.
- To program time based change-over commands for the net pressure band.
- Four different week schemes can be programmed.
- A week cycle can be programmed; a week cycle is a sequence of 10 weeks. For each week in the cycle, one of the four programmed week schemes can be chosen.

### Procedure

Starting from the Main screen (see [Main screen](#)),

- Move the cursor to the action button Menu and press the Enter key. Use the Scroll buttons to select the Timer icon.

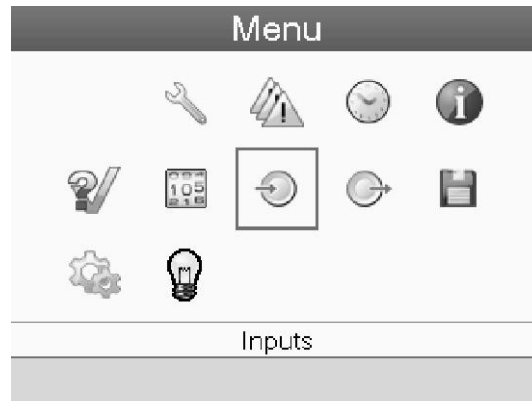

58536D

- Press the Enter key on the controller. Following screen appears:



58497D

Text on figure

|     |                        |
|-----|------------------------|
| (1) | Week Timer             |
| (2) | Week Action Schemes    |
| (3) | Week Cycle             |
| (4) | Status                 |
| (5) | Week 1                 |
| (6) | Remaining Running Time |

The first item in this list is highlighted in red. Select the item requested and press the Enter key on the controller to modify.

### Programming week schemes

- Select Week action schemes and press Enter. A new window opens. The first item in the list is highlighted in red. Press the Enter key on the controller to modify Week Action Scheme 1.

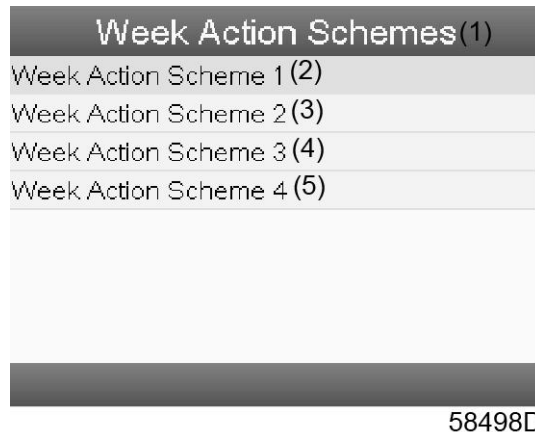

58498D

Text on figure

|     |                      |
|-----|----------------------|
| (1) | Week Action Schemes  |
| (2) | Week Action Scheme 1 |
| (3) | Week Action Scheme 2 |
| (4) | Week Action Scheme 3 |
| (5) | Week Action Scheme 4 |

- A weekly list is shown. Monday is automatically selected and highlighted in red. Press the Enter key on the controller to set an action for this day.

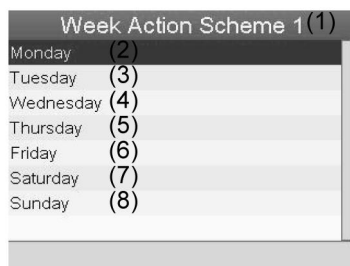

81488D

Text on figure

|     |                      |
|-----|----------------------|
| (1) | Week Action Scheme 1 |
| (2) | Monday               |
| (3) | Tuesday              |
| (4) | Wednesday            |
| (5) | Thursday             |
| (6) | Friday               |
| (7) | Saturday             |
| (8) | Sunday               |

- A new window opens. The Modify action button is selected. Press the Enter button on the controller to create an action.

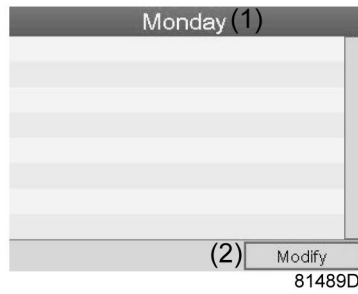

Text on figure

|     |        |
|-----|--------|
| (1) | Monday |
| (2) | Modify |

- A new pop-up window opens. Select an action from this list by using the Scroll keys on the controller. When ready press the Enter key to confirm.

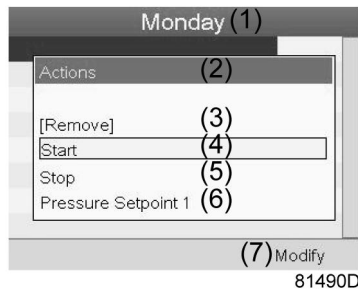

Text on figure

|     |                      |
|-----|----------------------|
| (1) | Monday               |
| (2) | Actions              |
| (3) | Remove               |
| (4) | Start                |
| (5) | Stop                 |
| (6) | Pressure Set point 1 |
| (7) | Modify               |

- A new window opens. The action is now visible in the first day of the week.

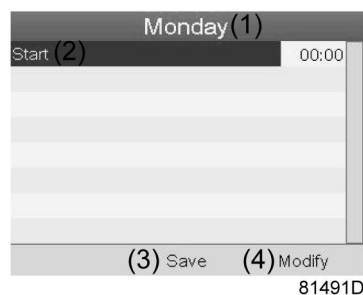

Text on figure

|     |        |
|-----|--------|
| (1) | Monday |
| (2) | Start  |
| (3) | Save   |
| (4) | Modify |

- To adjust the time, use the Scroll keys on the controller and press the Enter key to confirm.

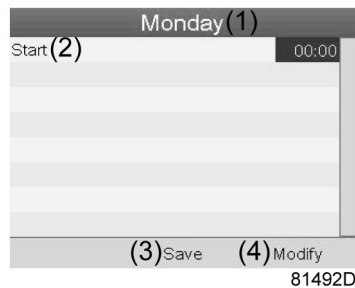

Text on figure

|     |        |
|-----|--------|
| (1) | Monday |
| (2) | Start  |
| (3) | Save   |
| (4) | Modify |

- A pop-up window opens. Use the ↑ or ↓ key of Scroll keys to modify the values of the hours. Use the ← or → Scroll keys to modify the minutes.

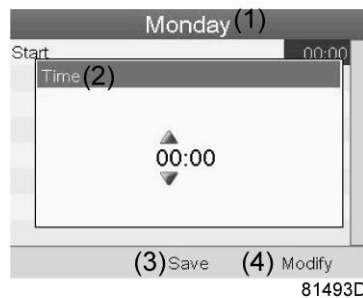

Text on figure

|     |        |
|-----|--------|
| (1) | Monday |
| (2) | Time   |
| (3) | Save   |
| (4) | Modify |

- Press the Escape key on the controller. The action button Modify is selected. Use the Scroll keys to select the action Save.

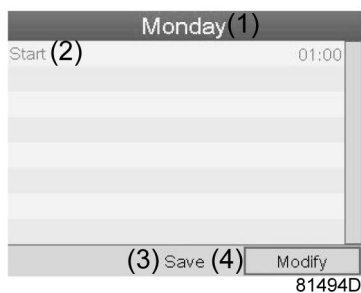

Text on figure

|     |        |
|-----|--------|
| (1) | Monday |
| (2) | Start  |
| (3) | Save   |
| (4) | Modify |

- A new pop-up window opens. Use the Scroll keys on the controller to select the correct actions. Press the Enter key to confirm.

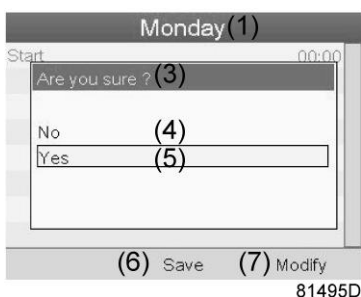

Text on figure

|     |               |
|-----|---------------|
| (1) | Monday        |
| (3) | Are you sure? |
| (4) | No            |
| (5) | Yes           |
| (6) | Save          |
| (7) | Modify        |

- Press the Escape key to leave this window.
- The action is shown below the day the action is planned.

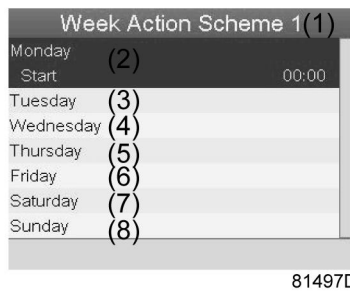

Text on figure

|     |                      |
|-----|----------------------|
| (1) | Week Action Scheme 1 |
| (2) | Monday - Start       |
| (3) | Tuesday              |
| (4) | Wednesday            |
| (5) | Thursday             |
| (6) | Friday               |
| (7) | Saturday             |
| (8) | Sunday               |

Press the Escape key on the controller to leave this screen.

### Programming the week cycle

A week cycle is a sequence of 10 weeks. For each week in the cycle, one of the four programmed week schemes can be chosen.

- Select Week Cycle from the main Week Timer menu list.

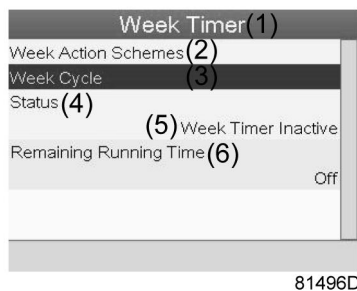

Text on figure

|     |                        |
|-----|------------------------|
| (1) | Week Timer             |
| (2) | Week Action Schemes    |
| (3) | Week Cycle             |
| (4) | Status                 |
| (5) | Week Timer Inactive    |
| (6) | Remaining Running Time |

- A list of 10 weeks is shown.

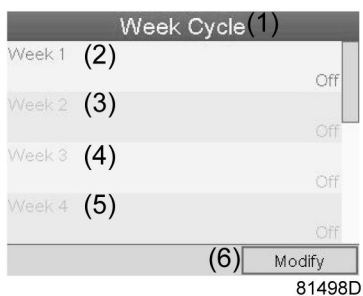

Text on figure

|     |            |
|-----|------------|
| (1) | Week Cycle |
| (2) | Week 1     |
| (3) | Week 2     |
| (4) | Week 3     |
| (5) | Week 4     |
| (6) | Modify     |

Press twice the Enter key on the controller to modify the first week.

- A new window opens. Select the action, example: Week Action Scheme 1

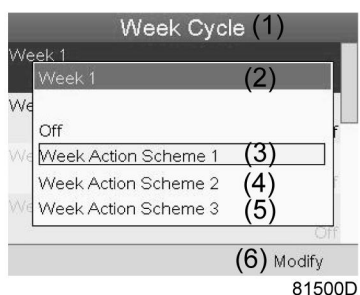

Text on figure

|     |                      |
|-----|----------------------|
| (1) | Week Cycle           |
| (2) | Week 1               |
| (3) | Week Action Scheme 1 |
| (4) | Week Action Scheme 2 |
| (5) | Week Action Scheme 3 |
| (6) | Modify               |

- Check the status of the Week Timer  
Use the Escape key on the controller to go back to the main Week Timer menu. Select the status of the Week Timer.

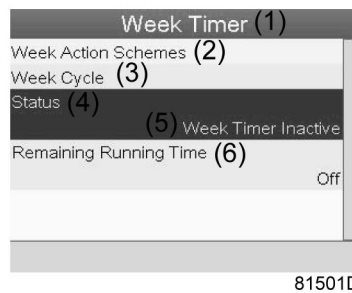

Text on figure

|     |                        |
|-----|------------------------|
| (1) | Week Timer             |
| (2) | Week Action Schemes    |
| (3) | Week Cycle             |
| (4) | Status                 |
| (5) | Week Timer Inactive    |
| (6) | Remaining Running Time |

- A new window opens. Select Week 1 to set the Week Timer active.

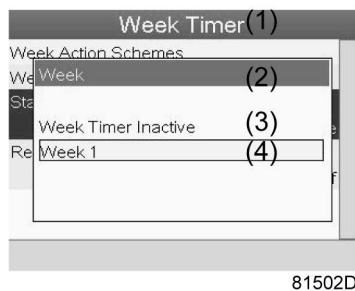

Text on figure

|     |                     |
|-----|---------------------|
| (1) | Week Timer          |
| (2) | Week                |
| (3) | Week Timer Inactive |
| (4) | Week 1              |

- Press the Escape key on the controller to leave this window. The status shows that week 1 is active.



Text on figure

|     |                        |
|-----|------------------------|
| (1) | Week Timer             |
| (2) | Week Action Schemes    |
| (3) | Week Cycle             |
| (4) | Status                 |
| (5) | Remaining Running Time |

- Press the Escape key on the controller to go to the main Week Timer menu. Select Remaining Running Time from the list and press the Enter key on the controller to Modify.



81504D

Text on figure

|     |                        |
|-----|------------------------|
| (1) | Week Timer             |
| (2) | Week Action Schemes    |
| (3) | Week Cycle             |
| (4) | Status                 |
| (5) | Remaining Running Time |

- This timer is used when the week timer is set and for certain reasons the dryer must continue working. The remaining running time, for example 1 hour, can be set in this screen. This timer is prior to the Week Timer action.



81505D

Text on figure

|     |                        |
|-----|------------------------|
| (1) | Week Timer             |
| (2) | Week action schemes    |
| (3) | Remaining Running Time |

## 5.14 Info menu

### Menu icon, Info



### Function

To show the Atlas Copco internet address.

### Procedure

Starting from the Main screen (see [Main screen](#)),

- Move the cursor to the action button Menu and press the Enter key. The following screen appears:

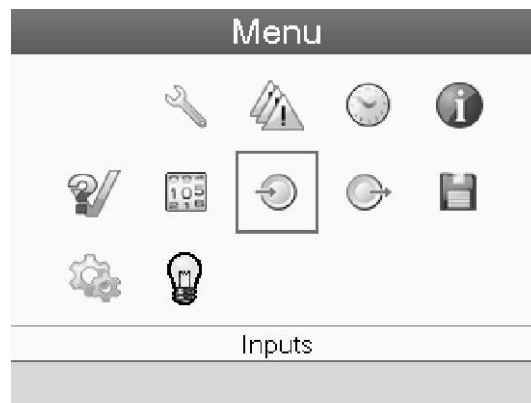

58536D

- Using the Scroll keys, move the cursor to the Info icon (see above, section Menu icon). The following screen appears:

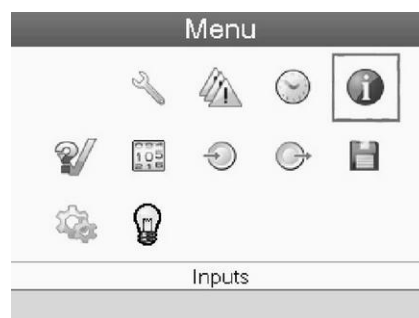

85807D

- Press the Enter key. Atlas Copco internet address appears on the screen.

## 5.15 Modifying settings

### Menu icon, Settings



**Function**

To display and modify a variety of settings (e.g. Time, Date, Date format, Language, Units, etc.).

**Procedure**

Starting from the Main screen (see section [Modifying Settings](#)):

- Move the cursor to the action button Menu and press the Enter key. Following screen appears:

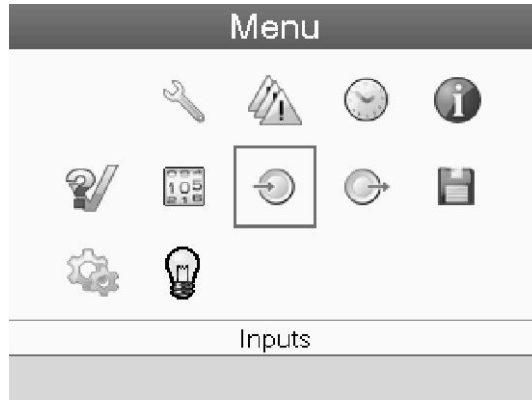

58536D

- Using the Scroll keys, move the cursor to the Settings icon (see Menu icon above for icon). The following screen appears:

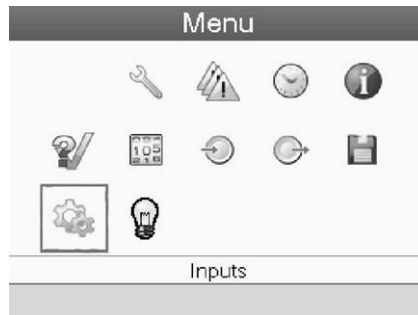





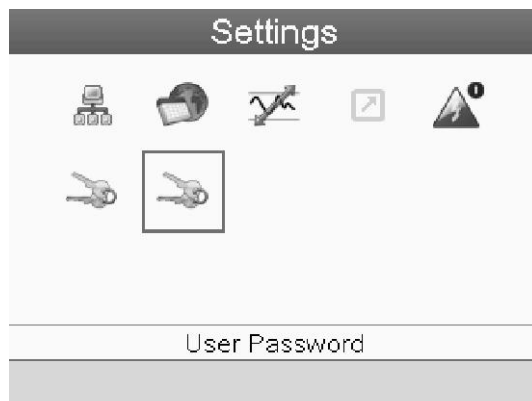

85808D

- Press the Enter key. The following screen appears:



58546D

- The screen shows a number of icons:

| Icon   | Function   |
|--|--|
|  57792F | Network settings   |
|  58470D | General settings   |
|  57820F | Regulation settings                                      |
|  57793F | Automatic restart after voltage failure (ARAVF) settings |
|  57819F | Access key   |
|  57819F | User password  |

- Move the cursor to the icon of the function to be modified and press the Enter key.

### Modifying network settings

- Select the network settings icon as described above and press the Enter button (2). The following screen appears:

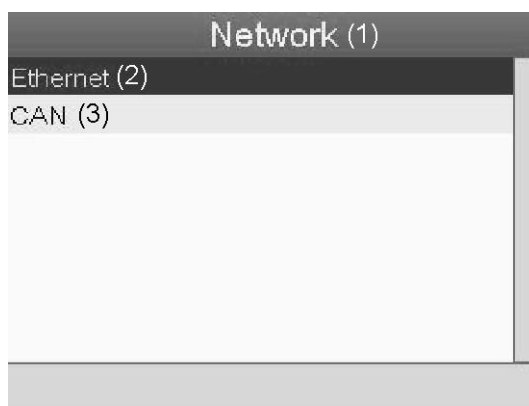

82089D

Text on figure

|     |          |
|-----|----------|
| (1) | Network  |
| (2) | Ethernet |
| (3) | CAN      |

- A red selection bar is covering the first item (Ethernet). Use the ↓ key of the Scroll keys to select the setting to be modified and press the Enter key. The following screen appears:

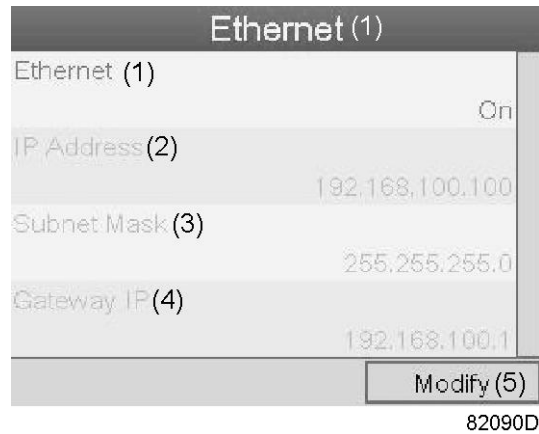

Screen for Ethernet settings

Text on figure

|     |             |
|-----|-------------|
| (1) | Ethernet    |
| (2) | IP Address  |
| (3) | Subnet mask |
| (4) | Gateway IP  |
| (5) | Modify      |

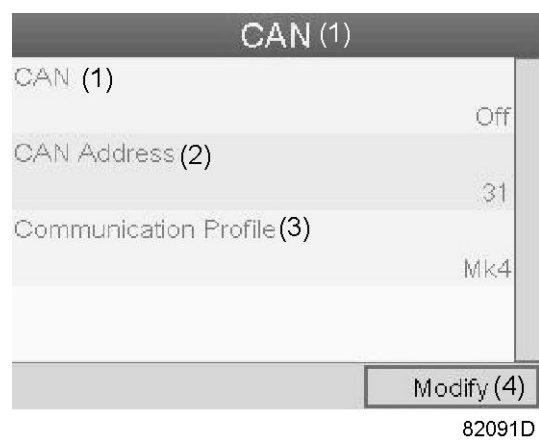

Screen for CAN settings

Text on figure

|     |                       |
|-----|-----------------------|
| (1) | CAN                   |
| (2) | CAN Address           |
| (3) | Communication profile |
| (4) | Modify                |

- Press the Enter button; a red selection bar is covering the first item (Ethernet).
- Using the Scroll keys, move the cursor to the setting to be modified (e.g. Ethernet) and press the Enter button (2).

- A pop-up screen appears. Use the ↑ or ↓ key to select the required parameter and press the Enter key to confirm.

**General settings**

- Select the General settings icon as described above and press the Enter button (2). The following screen appears:

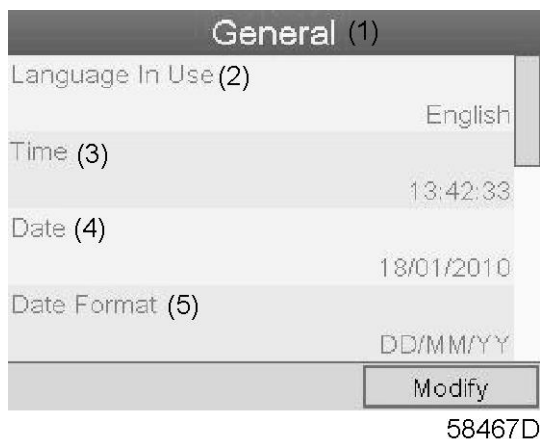

Text on figure

|     |                 |
|-----|-----------------|
| (1) | General         |
| (2) | Language in use |
| (3) | Time            |
| (4) | Date            |
| (5) | Date format     |

- The screen shows the first items of a list of all settings. Use the scroll button to see the other items in the list.
- Press the Enter button (2); a red selection bar is covering the first item (Language in use). Use the ↓ key of the Scroll keys to select the setting to be modified and press the Enter key.
- A pop-up screen appears. Use the ↑ or ↓ key to select the required parameter and press the Enter key to confirm.

**Regulation settings**

- Select the Regulation icon as described above and press the Enter button (2). The following screen appears:

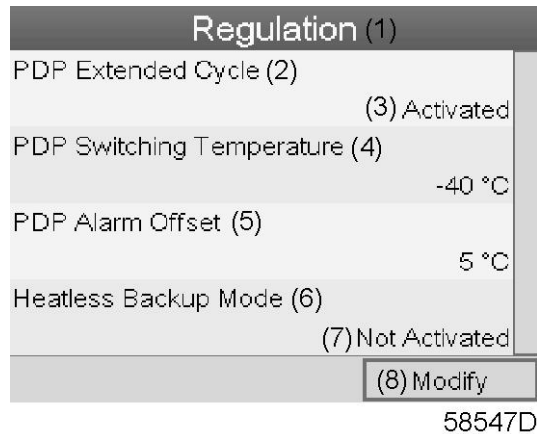

Text on figure

|     |  |
|-----|--|
| (1) | Regulation   |
| (2) | PDP Extended Cycle   |
| (3) | Activated  |
| (4) | PDP Switching Temperature  |
| (5) | PDP Alarm Offset   |
| (6) | Heatless Backup Mode (not applicable for this type of heatless dryers) |
| (7) | Not activated  |
| (8) | Modify   |
| (9) | Pulsed Purge Mode  |

- The screen shows the list of all settings.
- Press the Enter button (2); a red selection bar is covering the first item (PDP Extended Cycle).  
Use the ↓ key of the Scroll keys to select the setting to be modified and press the Enter key.
- A pop-up screen appears. Use the ↑ or ↓ key to select the required parameter and press the Enter key to confirm.

Regulation settings:

- **PDP Extended Cycle:** the cycle is lengthened by putting the vessel in waiting mode (standby) if PDP is low enough after regeneration and cooling.
- **PDP Switching Temperature:** the PDP should not increase to this setting before the vessels are switched when the dryer is in standby mode.
- **PDP Alarm Offset:** the PDP alarm is active when:  $PDP > PDP\_switching\_temperature + PDP\_alarm\_offset$ . In that way, the alarm threshold can be set independently of the switching threshold.

**Automatic restart**

- Select the Automatic restart settings icon as described above and press the Enter button (2). The following screen appears:

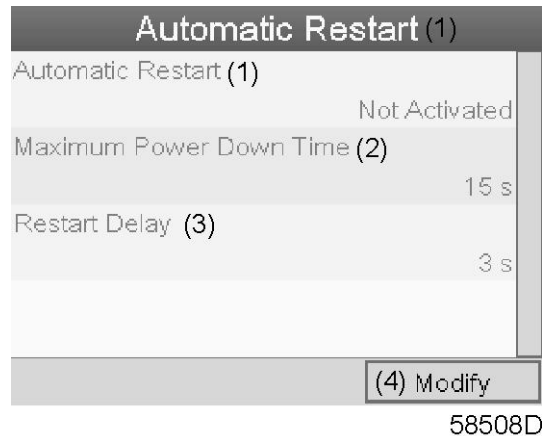

Text on figure

|     |                         |
|-----|-------------------------|
| (1) | Automatic Restart       |
| (2) | Maximum Power Down Time |
| (3) | Restart Delay           |
| (4) | Modify                  |

- The screen shows a list of all settings.
- Press the Enter button (2); a red selection bar is covering the first item (Automatic restart). Use the ↓ key of the Scroll keys to select the setting to be modified and press the Enter key.
- A pop-up screen appears. Use the ↑ or ↓ key to select the required parameter and press the Enter key to confirm.

### Access key

Different security levels are programmed in the regulator (e.g. user, service technician, etc). This menu item is used to change the security level. Scroll to the correct icon using the scroll key. Press the Enter button. Press the Enter button again to modify the security level. Press the Enter button again, a pop-up menu appears. Use the scroll keys to enter the password of the new security level. Press the Enter key to confirm the change.

### User password

If the password option is activated, it is impossible for not authorized persons to modify any setting.

- Using the Scroll keys, move the cursor to the Password icon.
- Press the Enter key.
- Select the Modify button using the Scroll keys and press the Enter key. Next, modify the password as required.

## 5.16 Extra menu

### Menu icon, Test



### Function

To call up the actual readings for pressure dew point, relative humidity, and LAT setpoint.

### Procedure

Starting from the Main screen (see [Main screen](#)):

- Move the cursor to the action button Menu and press the enter key (2). The following screen appears:

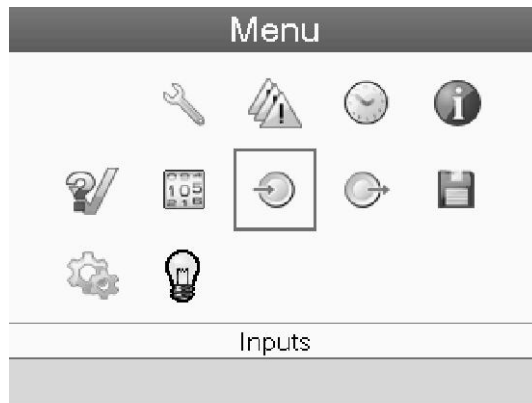

58536D

- Using the scroll keys (1), move the cursor to the Extra icon (see Menu icon for icon above). The following screen appears:

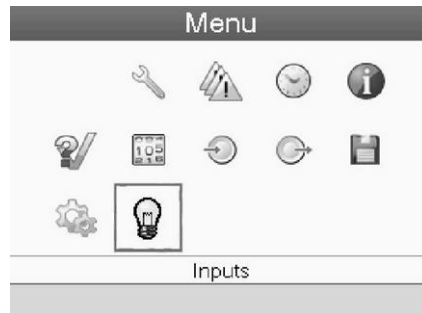

85809D

- Press the enter key (2). A screen showing the actual readings for the pressure dew point (PDP), the relative humidity and the LAT set point appears.

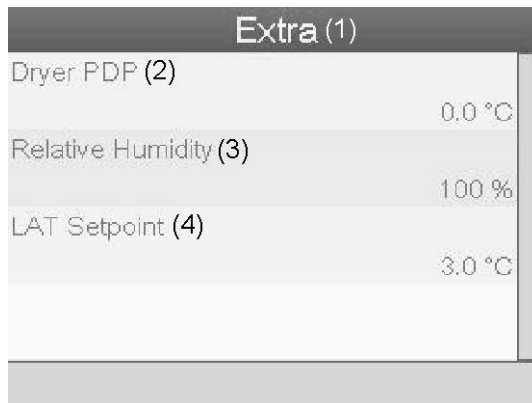

|     |                   |
|-----|-------------------|
| (1) | Extra             |
| (2) | Dryer PDP         |
| (3) | Relative Humidity |
| (4) | LAT Setpoint      |

## 5.17 Web server

The controllers have a built-in web server that allows direct connection to the company network or to a dedicated PC via a local area network (LAN). This allows to consult certain data and settings via a PC instead of via the display of the controller.

### Getting started

Make sure you are logged in as **administrator**.

- Use the internal network card from your computer or a USB to LAN adapter (see picture below).



*USB to LAN adapter (for Windows XP)*



59864F

*USB to LAN adapter (for Windows 7)*

- Use a UTP cable (CAT 5e) to connect to the controller (see picture below).



81508D

### **Configuration of the network card**

- Go to My Network places (1).

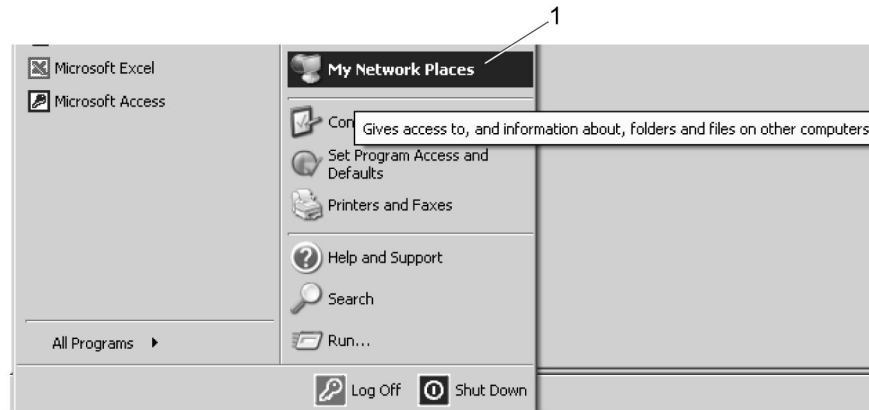

81509D

- Click on View Network connections (1).



81510D

- Select the Local Area connection (1), which is connected to the controller.

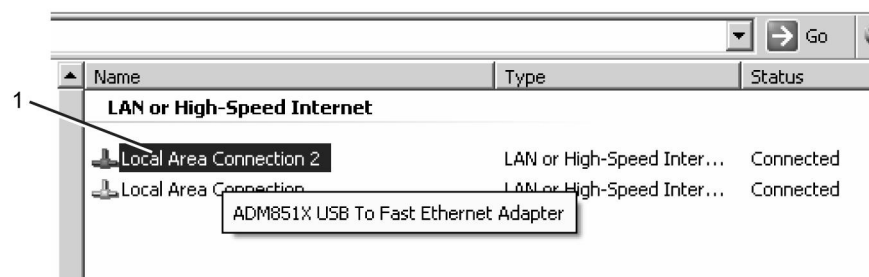

81511D

- Click with the right button and select properties (1).

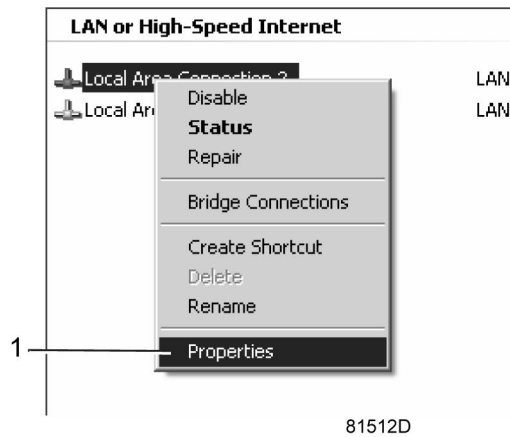

- Use the checkbox Internet Protocol (TCP/IP) (1) (see picture). To avoid conflicts, de-select other properties if they are selected. After selecting TCP/IP, click on the Properties button (2) to change the settings.

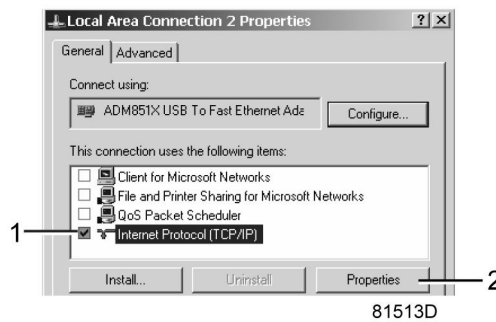

- Use the following settings:
  - IP Address 192.168.100.200
  - Subnetmask 255.255.255.0
 Click OK and close network connections.

## Configuration of the web server

### Configure the web interface

|   |  |
|---|--|
|  | <p>The internal web server is designed and tested for Microsoft® Internet Explorer 6, 7 and 8. Other web browsers like Opera and Firefox do not support this internal web server. When using Opera or Firefox, a redirect page opens. Click on the hyperlink to connect to the download server from Microsoft® to download the latest version of Internet Explorer, and install this software.</p> |
|---|--|

- When using Internet Explorer:  
Open Internet Explorer and click on Tools - Internet options (2).

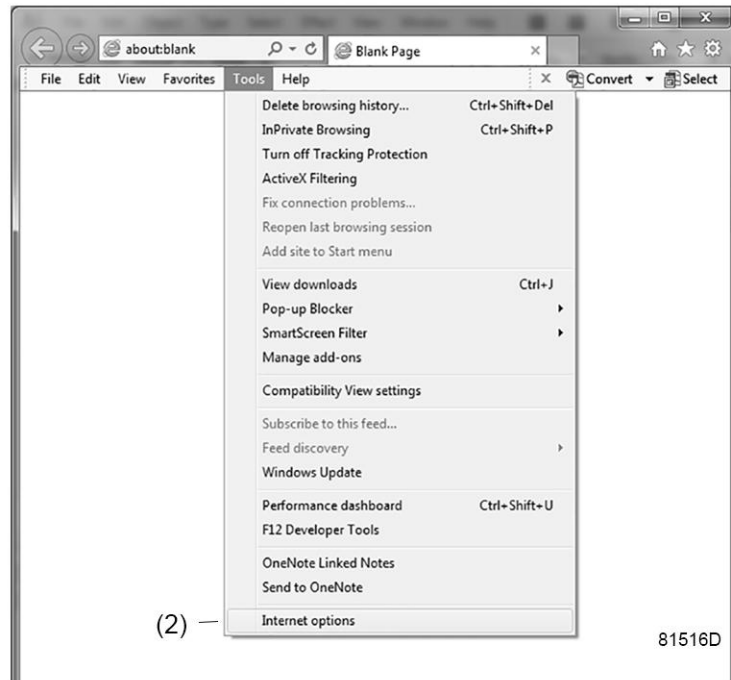

- Click on the Connections tab (1) and then click on the LAN settings button (2).

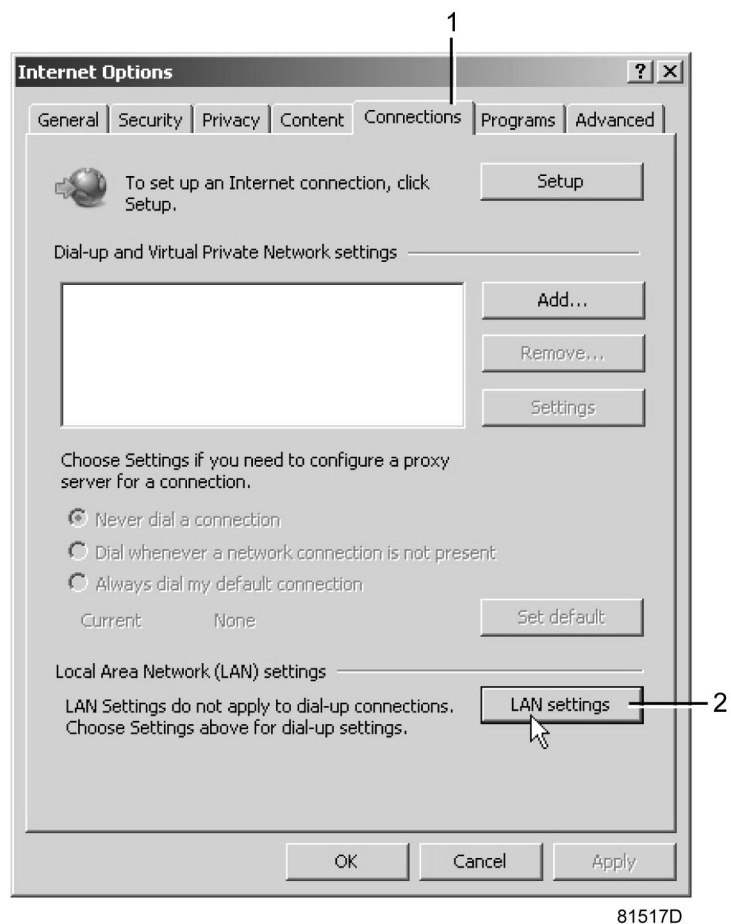

- In the Proxy server Group box, click on the Advanced button (1).

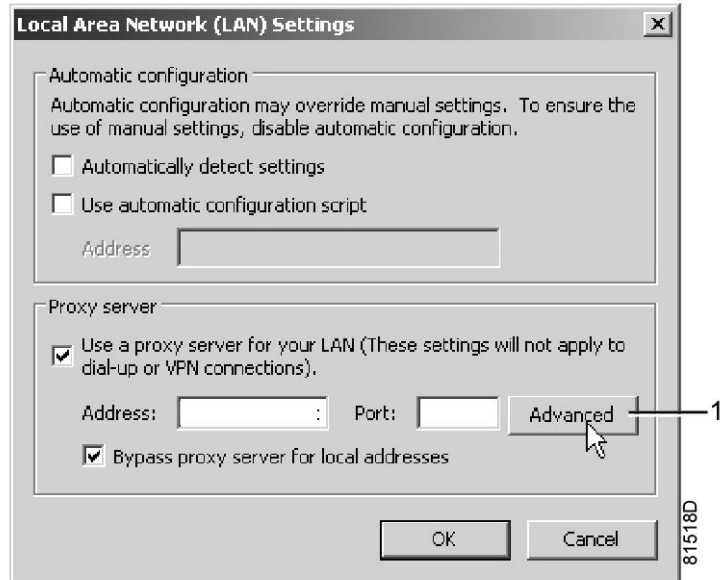

- In the Exceptions Group box, enter the IP address of your controller. Multiple IP addresses can be given but they must be separated with semicolons (;). Example: Suppose that you already added two IP addresses (192.168.100.1 and 192.168.100.2). Now you add 192.168.100.100 and separate the 3 IP addresses by putting semicolons between them (1) (see picture). Click OK (2) to close the window.

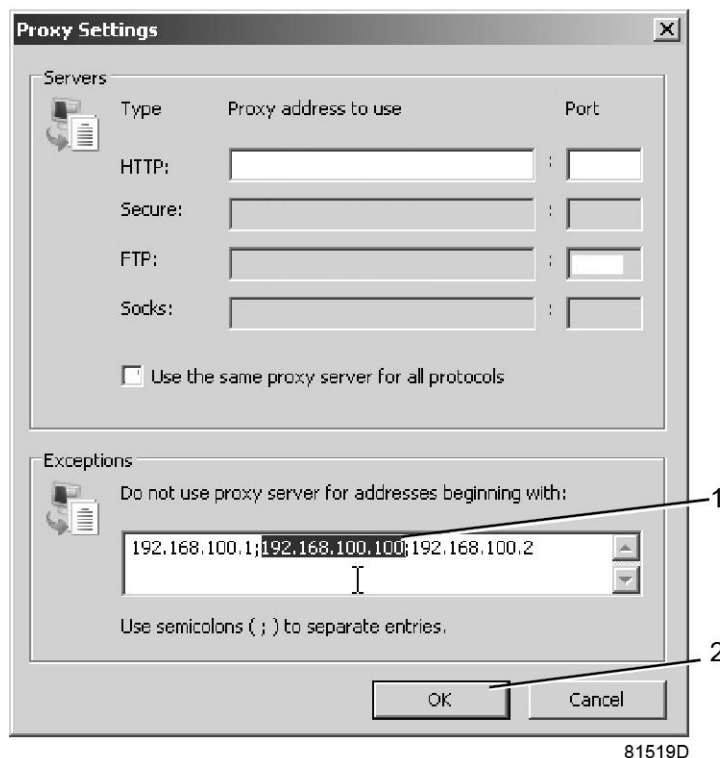

**Viewing the controller data**

- Open your browser and type the IP address of the controller you want to view in your browser (in this example <http://192.168.100.100>). The interface opens:

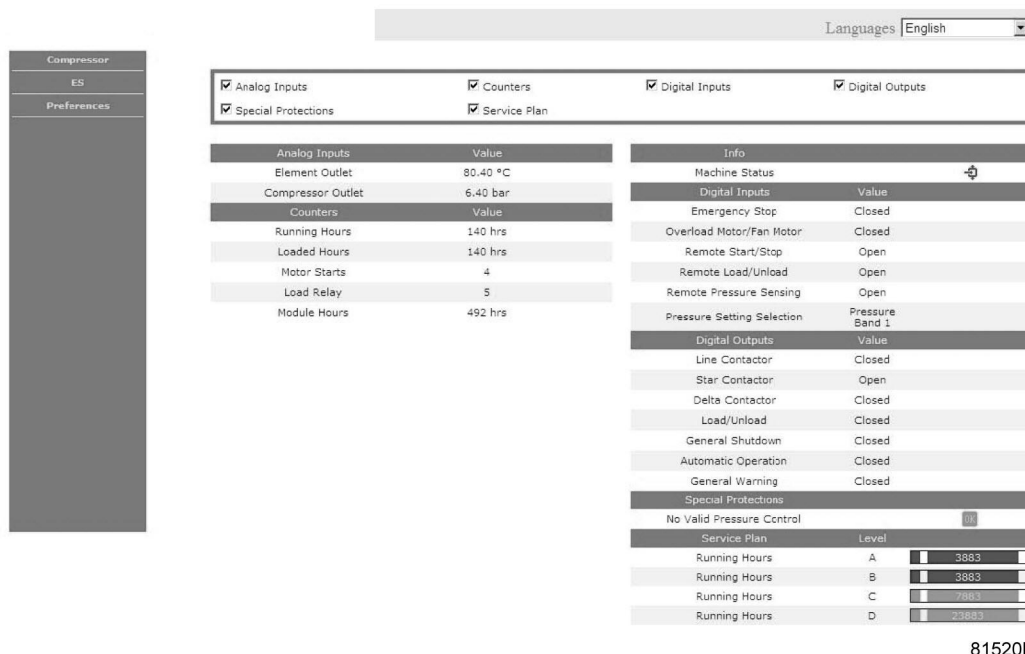

Controller screen (typical).

### Navigation and options

- The banner shows the machine type and the language selector. In this example, three languages are installed on the controller.



- On the left side of the interface you can find the navigation menu (see picture below). If a license for ESi is foreseen, the menu contains 3 buttons.
  - machine: shows all machine settings.
  - Es: shows the ESi status (if a license is provided).
  - Preferences: allows to change temperature and pressure unit.

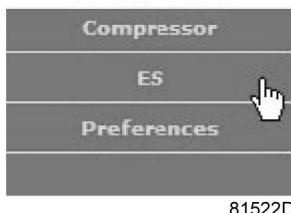

### Machine settings

All machine settings can be hidden or shown. Put a mark for each setting. Only the machine status is fixed and can not be removed from the main screen.

### Analog inputs

(The units of measure can be changed in the preference button from the navigation menu).

Analog Inputs

| Analog Inputs     | Value      |
|-------------------|------------|
| Element Outlet    | 131.90 °F  |
| Compressor Outlet | 110.21 psi |

81523D

### Counters

Counters give an overview of all actual counters from controller and machine.

Counters

| Counters      | Value   |
|---------------|---------|
| Running Hours | 29 hrs  |
| Loaded Hours  | 29 hrs  |
| Motor Starts  | 3       |
| Load Relay    | 4       |
| Module Hours  | 549 hrs |

81524D

### Info status

Machine status is always shown on the web interface.

Info

|                |
|----------------|
| Machine Status |
|----------------|

81525D

### Digital inputs

Gives an overview of all Digital inputs and status.

Digital Inputs

| Digital Inputs             | Value           |
|----------------------------|-----------------|
| Emergency Stop             | Closed          |
| Overload Motor/Fan Motor   | Closed          |
| Remote Start/Stop          | Open            |
| Remote Load/Unload         | Open            |
| Remote Pressure Sensing    | Open            |
| Pressure Setting Selection | Pressure Band 1 |

81526D

### Digital outputs

Shows a list of all digital outputs and their status.

Digital Outputs

| Digital Outputs     | Value  |
|---------------------|--------|
| Line Contactor      | Closed |
| Star Contactor      | Open   |
| Delta Contactor     | Closed |
| Load/Unload         | Closed |
| General Shutdown    | Closed |
| Automatic Operation | Closed |
| General Warning     | Closed |

81527D

### Special protections

Give an overview of all special protections of the machine.



### Service plan

Shows all levels of the service plan and status. This screen only shows the running hours. It is also possible to show the actual status of the service interval.

Service Plan

| Service Plan  | Level | Running Hours |
|---------------|-------|---------------|
| Running Hours | A     | 3971          |
| Running Hours | B     | 3971          |
| Running Hours | C     | 7971          |
| Running Hours | D     | 23971         |

81529D

### ES screen controller

If an ESi license is provided, the button ES is shown in the navigation menu. At the left all machines in the ES and at the right the ES status are shown.

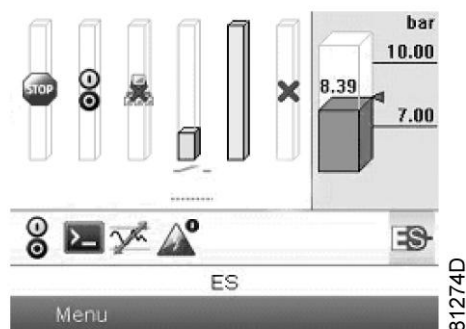

*A possible ESi screen*

## 5.18 Programmable settings

### Description

The regulation and safety devices are factory-adjusted to obtain optimum performance of the dryer. No adjustments are required.

## 6 Installation

### 6.1 Dimension drawings

The dimension drawings can be found in your technical documentation.

| Drawing number | Model        |
|----------------|--------------|
| 9827 8910 00   | CD 25 – 260+ |

| Text on drawing     | Description  |
|---------------------|--|
| INLET               | Dryer inlet connection                                 |
| OUTLET              | Dryer outlet connection                                |
| L (for dismantling) | Minimal free space to be foreseen for service purposes |

### 6.2 Installation proposal

#### General

|   |   |
|---|---|
|  | <p>The dryer is intended for indoor use and should be placed at least under a roof (protected against sun, wind and rain). The minimum ambient temperature mentioned on the data plate must be respected. See section <a href="#">Limitations for operation</a>.</p> <p>Install the dryer on a solid, level floor, suitable for taking its weight.</p> <p>Make sure to leave enough space (minimum 800 mm (2.6 ft)) around and above the dryer for servicing purposes. Consult the <a href="#">Dimension drawings</a>.</p> <p>Provide enough space under the filter elements so that the filter cartridges can be replaced without having to disassemble the piping.</p> <p>Make sure that all pipes, filters, valves, etc. are clean and that they are installed correctly with or without bypass system.</p> <p>Make sure that the piping is installed stress free.</p> <p>For more information concerning air nets, cooling systems, etc. refer to the compressor installation manual.</p> |
|---|---|

#### Instructions

To ensure correct operation, the dryer must be fitted properly into the compressed air circuit, consisting of the compressor, the dryer and the application.

- Water separator (3) : A high-efficiency water separator removes 90 % of the free water in the compressed air. If not mounted in the compressor, a water separator needs to be installed between the compressor and the air receiver or the dryer inlet filter (whichever comes first).
- It is recommended to install a general purpose inlet filter upstream of the dryer to remove liquid oil.  
A high-efficiency filter (4) (delivered with the dryer (5)) removes particles from the compressed air down to 0.01 micron and removes the remaining oil (maximum oil carry-over of 0.01 ppm).

On both inlet filters a drain tube must be installed. The drain tubes (8) to the drain collector must not dip into the water.

Install an oil/water separator to drain pure condensate water. Consult your supplier.

- A dust filter (6) (delivered with the dryer) at the dryer outlet removes particles down to 1 micron.

Should oil vapor and odors be undesirable, a carbon filter can be installed downstream the outlet dust filter.

- It is advisable to install bypass pipes with ball valves over the filters in order to isolate the filters during service operations without disturbing the compressed air delivery.
- It is recommended to install a ball valve (7) after the dryer. This valve should be closed at startup to ensure pressure is built up. The valve can be left open when the pressure remains in the dryer.
- If the maximum pressure of the compressor is higher than the design pressure of the dryer, a full flow safety valve must be installed between the compressor and the dryer in order to blow off the excessive pressure.

Refer to the images below for the references used.

|   |   |
|---|---|
|  | <p><b>Never overload the dryer as a too high air speed may damage the desiccant. It is recommended to install the air dryer upstream of the air receiver to prevent overload</b> (e.g. after extending the dry air circuit). Consult your supplier if in doubt. See section <a href="#">Operating instructions</a> for the correct operation procedure.</p> |
|---|---|

Depending on whether compressor synchronization contact (connector X2 on the controller) is used (see also section [Operation](#)), there are two possibilities for dryers equipped with the DC1 controller:

### Installation in case X2 is not connected

|   |  |
|---|--|
|  | <p><b>If the freeze contact X2 is not used</b>, the correct order of installation is compressor - air receiver - dryer.<br/>                 The entire compressed air flow from the compressor is stored in an air receiver. Only the air that needs to be dried passes the dryer.<br/>                 In case the air receiver is installed upstream the dryer and the load/unload contact of the compressor is connected to X2, the dryer may get overloaded by the air receiver's air volume when it is in freeze mode.<br/> <b>An external contact may only be connected to the X2 contact of the dryer when the air receiver is placed downstream of the dryer.</b></p> |
|---|--|

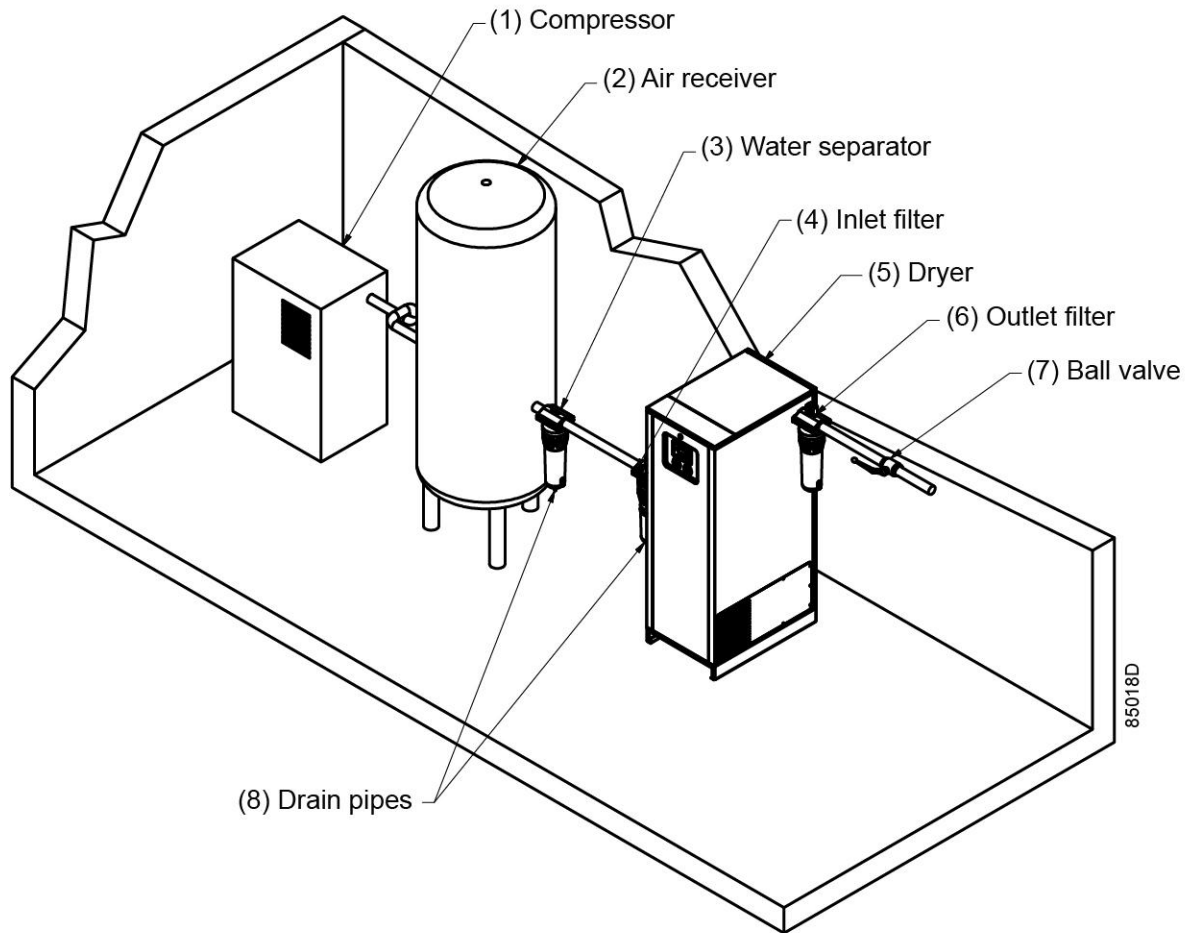

### Installation in case X2 is connected



The entire flow from the compressor passes the dryer. The dry air is stored in the air receiver downstream of the dryer.  
 With X2 connected, the dryer will stop the purge air flow at the end of the cycle. (< 2 minutes) and it will restart when the air compressor resumes to deliver compressed air.  
**When the air receiver is installed upstream the dryer, the load/unload contact of the compressor must not be connected to X2. The dryer could get overloaded by the air receiver's air volume when it is in freeze mode.**

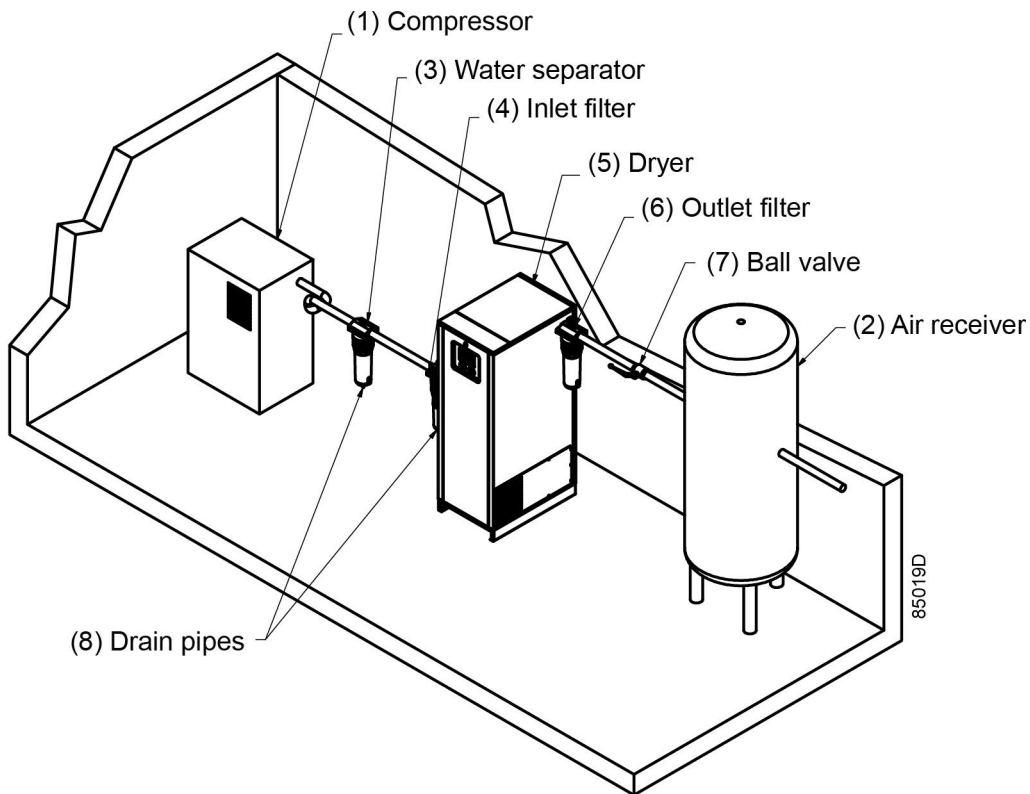

## 7 Electrical connections

### General



The electrical wiring must comply with the local regulations. The air dryer must be earthed and protected by fuses against short-circuiting. Consult the electric diagram delivered with the dryer.

Before switching on the main power supply, check the voltage requirements in the technical specifications or on the dryer's data plate.

## 8 Operating instructions

### Safety



Always observe all relevant safety instructions.

### Initial start-up

To start up the dryer for the first time or after a long period of standstill, proceed as follows:

1. If installed, open the bypass valves of the dryer.
2. Close the air supply towards the pressure dew point (PDP) sensor.
3. Close off the air supply from the compressor towards the dryer by closing the external inlet valve (if installed).
4. If installed, close the outlet valve.
5. Start the compressor and wait for pressure.
6. Slowly open the inlet valve.
7. Check the connections of the dryer for air leaks and remedy if necessary.
8. Switch the dryer on by pushing the Start button on the controller.
9. Let the dryer operate for several hours with the external outlet valve closed.
10. Gradually open the external outlet valve.
11. If applicable, close the bypass valves of the dryer.
12. Open the air supply towards the pressure dew point (PDP) sensor.



If the application allows air that is not completely dry, the valve towards the dry air consumer may be opened even before the optimal Pressure Dew Point (PDP) is reached. In this case, however, it will take more time for the desiccant to dry the air completely.

At initial start-up, and especially when the dryer is loaded from the beginning, it can take a long time before the dew point is reached.

For a dew point of  $-70\text{ °C}$  ( $-94\text{ °F}$ ), it can take up to more than 10 days before this value is reached.

It is therefore recommended to operate the dryer for a number of days with the outlet valve closed.

### Normal start

If the dryer has not been used for more than 3 months, refer to section Initial startup. In all other cases, proceed as follows:

1. Cut off the air supply from the compressor towards the dryer by closing the external inlet valve.
2. Close the air supply towards the PDP sensor.
3. If installed, close the external outlet valve between the dryer and the dry air consumer.
4. Start the compressor and slowly open the external inlet valve.
5. Switch on the dryer.
6. Gradually open the air outlet valve.
7. If applicable, close the bypass valves of the dryer.
8. Open the air supply towards the PDP sensor.



Close the external inlet valve in case the compressor needs to be restarted. The high air speed in the startup phase of the compressor may damage the desiccant.

## During operation



The LEDs for PDP warning and PDP alarm are only functional if the dryer is equipped with a PDP sensor!

## Stopping

To stop the dryer, proceed as follows:

1. If installed and if necessary, open the bypass valves of the dryer so that the application will still receive compressed air.
2. Close the external inlet valve between the compressor and the dryer and the external outlet valve between the dryer and the dry air consumer.
3. Let the dryer operate for a period without consumption, to depressurize the vessels.
4. Switch off the dryer.



If the dryer is stopped for a longer period, keep the external inlet and outlet valve closed to avoid moisture from entering the dryer.  
Under no circumstances shall compressed air be allowed to flow through the dryer when the electrical power is switched off. This will result in terminal failure of the desiccant material and regeneration will no longer be possible.

## 9 Maintenance

### 9.1 Maintenance

#### General recommendations and precautions

Before carrying out any maintenance or corrective activity, read the following recommendations and safety precautions and proceed accordingly.

- Stop the dryer by pushing the Stop button on the controller.
- Disconnect all pressure sources and vent the internal pressure of the system before dismantling any pressurized component.
- Use genuine Atlas Copco spare parts only. Consult the Spare Parts List for part numbers. For preventive maintenance, dedicated service kits are available.
- Check for correct operation after maintenance.

|   |   |
|---|---|
|  | Filters and valves installed between the compressor, the dryer and the air consumer may need other maintenance activities than those mentioned below (e.g. draining the filters and replacing the filter elements). Refer to the appropriate manual for more information. |
|---|---|

#### Preventive maintenance schedule

| Frequency   | Service plan | Activity   |
|---|--------------|--|
| Daily   |              | Check the display panel for information and service messages.  |
| Every 6 months or every 4000 hours of operation (1) | A            | <ul style="list-style-type: none"> <li>• Check for damaged wiring or loose connections.</li> <li>• Check for air leaks.</li> <li>• Replace the in- and outlet filter cartridges (if installed).</li> <li>• Replace the blow off silencer.</li> <li>• Replace regeneration silencer (if installed).</li> </ul>  |
| Every year or every 8000 hours of operation (1)     | B            | <ul style="list-style-type: none"> <li>• Service plan A.</li> <li>• Calibrate/replace pressure dewpoint (PDP) sensor (if installed).</li> </ul>  |
| Every five years or every 40000 hours (1)           | C            | <ul style="list-style-type: none"> <li>• Service plan B.</li> <li>• Replace the desiccant.</li> <li>• Replace the blow off valve.</li> <li>• Replace the regeneration angle seat valve (if installed).</li> <li>• Replace the regeneration solenoid valve (if installed).</li> </ul> <p>Always replace all O-rings, seals and nylon washers that come free when executing the scheduled maintenance.</p> |

(1) whichever comes first

In normal working conditions, the lifetime of the desiccant is approximately 5 years.

It is recommended to have the desiccant replaced by a qualified Atlas Copco service technician.

Reset the service timer after a maintenance intervention.

All spare parts required for scheduled maintenance are included in specific service kits. Consult the Spare Parts List for part number information.

## 9.2 Nozzle replacement

### Procedure

1. Open the top panel to access the nozzles.  
The nozzles are located on the top of the upper manifold.
2. Release the push-fits on the elbow fittings and pull and bend out the assembly of the nozzle, straight couplings and tubes.
3. Select the new nozzle according to the working pressure. See recommendation table below.
4. Place the assembly back in the elbow fittings.
5. Put all of the spare nozzles back in the bag inside the unit in case of future operating changes.

Recommendation table

| Model  | PDP |      | Bar (g) |      |      |      |      |      |
|--------|-----|------|---------|------|------|------|------|------|
|        | °C  | °F   | 4.0     | 5.5  | 7.0  | 8.5  | 10.0 | 13.0 |
| CD25+  | -70 | -100 | 0.21    | 0.17 | 0.14 | 0.12 | 0.10 | 0.07 |
| CD35+  | -70 | -100 | 0.28    | 0.23 | 0.19 | 0.16 | 0.14 | 0.11 |
| CD45+  | -70 | -100 | 0.33    | 0.28 | 0.23 | 0.20 | 0.18 | 0.14 |
| CD55+  | -70 | -100 | 0.23    | 0.18 | 0.15 | 0.13 | 0.11 | 0.08 |
| CD65+  | -70 | -100 | 0.26    | 0.21 | 0.18 | 0.15 | 0.13 | 0.10 |
| CD90+  | -70 | -100 | 0.33    | 0.28 | 0.23 | 0.20 | 0.18 | 0.14 |
| CD110+ | -70 | -100 | 0.29    | 0.23 | 0.20 | 0.17 | 0.15 | 0.12 |
| CD130+ | -70 | -100 | 0.33    | 0.28 | 0.24 | 0.20 | 0.18 | 0.14 |
| CD165+ | -70 | -100 | 0.32    | 0.27 | 0.23 | 0.20 | 0.17 | 0.14 |
| CD195+ | -70 | -100 | 0.37    | 0.31 | 0.27 | 0.23 | 0.21 | 0.17 |
| CD25+  | -40 | -40  | 0.15    | 0.12 | 0.09 | 0.07 | 0.06 | 0.04 |
| CD35+  | -40 | -40  | 0.21    | 0.16 | 0.13 | 0.11 | 0.09 | 0.07 |
| CD45+  | -40 | -40  | 0.25    | 0.20 | 0.17 | 0.15 | 0.12 | 0.09 |
| CD55+  | -40 | -40  | 0.29    | 0.23 | 0.20 | 0.17 | 0.15 | 0.12 |
| CD65+  | -40 | -40  | 0.32    | 0.27 | 0.23 | 0.20 | 0.17 | 0.14 |
| CD90+  | -40 | -40  | 0.25    | 0.20 | 0.17 | 0.15 | 0.12 | 0.09 |
| CD110+ | -40 | -40  | 0.29    | 0.24 | 0.20 | 0.18 | 0.15 | 0.12 |
| CD130+ | -40 | -40  | 0.33    | 0.27 | 0.23 | 0.20 | 0.18 | 0.14 |
| CD165+ | -40 | -40  | 0.29    | 0.24 | 0.20 | 0.18 | 0.15 | 0.12 |
| CD195+ | -40 | -40  | 0.34    | 0.28 | 0.24 | 0.21 | 0.18 | 0.15 |
| CD260+ | -40 | -40  | 0.34    | 0.28 | 0.24 | 0.21 | 0.18 | 0.15 |
| CD25+  | -20 | -4   | 0.15    | 0.11 | 0.09 | 0.07 | 0.05 | 0.03 |
| CD35+  | -20 | -4   | 0.20    | 0.16 | 0.13 | 0.11 | 0.09 | 0.06 |
| CD45+  | -20 | -4   | 0.25    | 0.20 | 0.17 | 0.14 | 0.12 | 0.09 |
| CD55+  | -20 | -4   | 0.29    | 0.23 | 0.20 | 0.17 | 0.15 | 0.12 |
| CD65+  | -20 | -4   | 0.32    | 0.27 | 0.23 | 0.20 | 0.17 | 0.14 |
| CD90+  | -20 | -4   | 0.41    | 0.34 | 0.29 | 0.26 | 0.23 | 0.19 |
| CD110+ | -20 | -4   | 0.29    | 0.23 | 0.20 | 0.17 | 0.15 | 0.12 |
| CD130+ | -20 | -4   | 0.32    | 0.27 | 0.23 | 0.20 | 0.17 | 0.14 |

| Model  | PDP |    | Bar (g) |      |      |      |      |      |
|--------|-----|----|---------|------|------|------|------|------|
|        | °C  | °F | 4.0     | 5.5  | 7.0  | 8.5  | 10.0 | 13.0 |
| CD165+ | -20 | -4 | 0.38    | 0.32 | 0.27 | 0.24 | 0.21 | 0.17 |
| CD195+ | -20 | -4 | 0.32    | 0.27 | 0.23 | 0.20 | 0.17 | 0.14 |
| CD260+ | -20 | -4 | 0.40    | 0.33 | 0.28 | 0.25 | 0.22 | 0.18 |

## 10 Problem solving

### Overview

| Fault  | Cause  | Remedy   |
|--|--|--|
| Pressure dew point too high<br>LED PDP warning/PDP alarm is lit. | The dryer has not had the time to regenerate completely. | Close the valve installed between the dryer and the application (if permitted) and have the desiccant regenerated.   |
|  | The silencers are clogged.                               | Replace the silencers.   |
|  | The drain is not working correctly.                      | Check the drain valve of the filter.   |
|  | The air flow through the dryer is too high.              | Check for correct application.   |
|  | The outlet pressure is too low.                          | Check whether the compressor provides enough air for the application.  |
|  | The inlet temperature is too high.                       | Check the compressor aftercooler.  |
|  | Free water in the dryer.                                 | Check the water separator and the drain valve of the filters upstream of the dryer.  |
| The dryer produces a lot of noise.                               | Check the silencer and its fixation to the unit.         | Replace the silencer if necessary or correct its fixation.   |
| Insufficient air leaves the dryer.                               | Too much purge air escapes.                              | Check the condition of the solenoid valve and replace it if necessary.<br>Check if the correct nozzle is installed (standard nozzle supplied is for 7 bar, alternative nozzles are available for other operating pressures). |

## 11 Technical data

### 11.1 Reference conditions

| Condition                               | Unit | Value |
|---|------|-------|
| Compressed air effective inlet pressure | barg | 7     |
|   | psig | 101.5 |
| Compressed air inlet temperature        | °C   | 35    |
|   | °F   | 95    |
| Relative humidity of the air at inlet   | %    | 100   |
| Pressure dew point (PDP —20 °C version) | °C   | -20   |
|   | °F   | -4    |
| Pressure dew point (PDP —40 °C version) | °C   | -40   |
|   | °F   | -40   |
| Pressure dew point (PDP —70 °C version) | °C   | -70   |
|   | °F   | -94   |

### 11.2 Limitations for operation

| Limitation                                      | Unit                             | Value |
|---|----------------------------------|-------|
| Maximum compressed air effective inlet pressure | barg                             | 14    |
| Maximum compressed air effective inlet pressure | psig                             | 203   |
| Minimum compressed air effective inlet pressure | barg                             | 4     |
| Minimum compressed air effective inlet pressure | psig                             | 58    |
| Maximum ambient air temperature                 | °C                               | 45    |
| Maximum ambient air temperature                 | °F                               | 113   |
| Minimum ambient air temperature                 | °C                               | 1     |
| Minimum ambient air temperature                 | °F                               | 34    |
| Maximum compressed air inlet temperature        | °C                               | 50    |
| Maximum compressed air inlet temperature        | °F                               | 122   |
| Minimum compressed air inlet temperature        | °C                               | 2     |
| Minimum compressed air inlet temperature        | °F                               | 36    |
| Minimum volume flow at inlet                    | See <a href="#">Dryer data</a> . |       |

## 11.3 Dryer data

### High Efficiency (+) version, PDP -20 °C

|                                      |     | CD 25+            | CD 35+            | CD 45+            | CD 55+            | CD 65+            | CD 90+            |
|--------------------------------------|-----|-------------------|-------------------|-------------------|-------------------|-------------------|-------------------|
| Volume flow at dryer inlet           | l/s | 25                | 35                | 45                | 55                | 65                | 90                |
| Volume flow at dryer inlet           | cfm | 53                | 74                | 95                | 116               | 138               | 191               |
| Pressure drop at maximum flow        | bar | 0.031             | 0.060             | 0.107             | 0.171             | 0.251             | 0.532             |
| Pressure drop at maximum flow        | psi | 0.45              | 0.87              | 1.55              | 2.48              | 3.64              | 7.72              |
| Time to half a cycle                 | s   | 87                | 87                | 87                | 87                | 87                | 87                |
| Regeneration time                    | s   | 65                | 65                | 65                | 65                | 65                | 65                |
| Pressurization time                  | s   | 20                | 20                | 20                | 20                | 20                | 20                |
| Average regeneration air consumption | %   | 16                | 16                | 16                | 16                | 16                | 16                |
| Desiccant type                       |     | Activated alumina | Activated alumina | Activated alumina | Activated alumina | Activated alumina | Activated alumina |
| Desiccant amount per vessel          | kg  | 7.4               | 7.4               | 9.9               | 12.4              | 14.8              | 18.8              |
| Desiccant amount per vessel          | lb  | 16.3              | 16.3              | 21.8              | 27.3              | 32.6              | 41.45             |
| Inlet filter 1                       |     | UD 25+            | UD 45+            | UD 45+            | UD 60+            | UD 100+           | UD 100+           |
| Outlet filter 1                      |     | DDp 35+           | DDp 50+           | DDp 50+           | DDp 70+           | DDp 70+           | DDp 70+           |
| Maximum air outlet temperature       | °C  | 60                | 60                | 60                | 60                | 60                | 60                |
| Maximum air outlet temperature       | °F  | 140               | 140               | 140               | 140               | 140               | 140               |
| Minimum volume flow at inlet         | l/s | 6.25              | 8.75              | 11.25             | 13.75             | 16.25             | 22.5              |
| Minimum volume flow at inlet         | cfm | 13.25             | 18.55             | 23.85             | 29.15             | 34.45             | 47.7              |

|                               |     | CD 110+ | CD 130+ | CD 165+ | CD 195+ | CD 260+ |
|-------------------------------|-----|---------|---------|---------|---------|---------|
| Volume flow at dryer inlet    | l/s | 110     | 130     | 165     | 195     | 260     |
| Volume flow at dryer inlet    | cfm | 233     | 275     | 350     | 413     | 551     |
| Pressure drop at maximum flow | bar | 0.171   | 0.251   | 0.447   | 0.251   | 0.494   |
| Pressure drop at maximum flow | psi | 2.48    | 3.64    | 6.48    | 3.64    | 7.16    |

|                                      |     | <b>CD 110+</b>    | <b>CD 130+</b>    | <b>CD 165+</b>    | <b>CD 195+</b>    | <b>CD 260+</b>    |
|--------------------------------------|-----|-------------------|-------------------|-------------------|-------------------|-------------------|
| Time to half a cycle                 | s   | 87                | 87                | 87                | 87                | 87                |
| Regeneration time                    | s   | 65                | 65                | 65                | 65                | 65                |
| Pressurization time                  | s   | 20                | 20                | 20                | 20                | 20                |
| Average regeneration air consumption | %   | 16                | 16                | 16                | 16                | 16                |
| Desiccant type                       |     | Activated alumina | Activated alumina | Activated alumina | Activated alumina | Activated alumina |
| Desiccant amount per vessel          | kg  | 12.4              | 14.8              | 18.8              | 14.8              | 18.8              |
| Desiccant amount per vessel          | lb  | 27.3              | 32.6              | 41.4              | 32.6              | 41.4              |
| Inlet filter 1                       |     | UD 140+           | UD 140+           | UD 180+           | UD 220+           | UD 310+           |
| Outlet filter 1                      |     | DDp 130+          | DDp 130+          | DDp 170+          | DDp 210+          | DDp 310+          |
| Maximum air outlet temperature       | °C  | 60                | 60                | 60                | 60                | 60                |
| Maximum air outlet temperature       | °F  | 140               | 140               | 140               | 140               | 140               |
| Minimum volume flow at inlet         | l/s | 27.5              | 32.5              | 41.25             | 48.75             | 65                |
| Minimum volume flow at inlet         | cfm | 58.3              | 68.9              | 87.45             | 103.35            | 137.8             |

### High Efficiency (+) version, PDP -40 °C

|                                      |     | <b>CD 25+</b>     | <b>CD 35+</b>     | <b>CD 45+</b>     | <b>CD 55+</b>     | <b>CD 65+</b>     | <b>CD 90+</b>     |
|--------------------------------------|-----|-------------------|-------------------|-------------------|-------------------|-------------------|-------------------|
| Volume flow at dryer inlet           | l/s | 25                | 35                | 45                | 55                | 65                | 90                |
| Volume flow at dryer inlet           | cfm | 53                | 74                | 95                | 116               | 138               | 191               |
| Pressure drop at maximum flow        | bar | 0.031             | 0.065             | 0.114             | 0.180             | 0.278             | 0.114             |
| Pressure drop at maximum flow        | psi | 0.45              | 0.94              | 1.65              | 2.61              | 4.03              | 1.65              |
| Time to half a cycle                 | s   | 87                | 87                | 87                | 87                | 87                | 87                |
| Regeneration time                    | s   | 65                | 65                | 65                | 65                | 65                | 65                |
| Pressurization time                  | s   | 20                | 20                | 20                | 20                | 20                | 20                |
| Average regeneration air consumption | %   | 16.5              | 16.5              | 16.5              | 16                | 16                | 16.5              |
| Desiccant type                       |     | Activated alumina | Activated alumina | Activated alumina | Activated alumina | Activated alumina | Activated alumina |
| Desiccant amount per vessel          | kg  | 7.4               | 9.9               | 12.4              | 14.8              | 18.8              | 12.4              |

|                                |     | <b>CD 25+</b> | <b>CD 35+</b> | <b>CD 45+</b> | <b>CD 55+</b> | <b>CD 65+</b> | <b>CD 90+</b> |
|--------------------------------|-----|---------------|---------------|---------------|---------------|---------------|---------------|
| Desiccant amount per vessel    | lb  | 16.3          | 21.8          | 27.3          | 32.6          | 41.4          | 27.3          |
| Inlet filter 1                 |     | UD 25+        | UD 45+        | UD 45+        | UD 60+        | UD 100+       | UD 100+       |
| Outlet filter 1                |     | DDp 35+       | DDp 50+       | DDp 50+       | DDp 70+       | DDp 70+       | DDp 70+       |
| Maximum air outlet temperature | °C  | 60            | 60            | 60            | 60            | 60            | 60            |
| Maximum air outlet temperature | °F  | 140           | 140           | 140           | 140           | 140           | 140           |
| Minimum volume flow at inlet   | l/s | 6.25          | 8.75          | 11.25         | 13.75         | 16.25         | 22.5          |
| Minimum volume flow at inlet   | cfm | 13.25         | 18.55         | 23.85         | 29.15         | 34.45         | 47.7          |

|                                      |     | <b>CD 110+</b>    | <b>CD 130+</b>    | <b>CD 165+</b>    | <b>CD 195+</b>    | <b>CD 260+</b>    |
|--------------------------------------|-----|-------------------|-------------------|-------------------|-------------------|-------------------|
| Volume flow at dryer inlet           | l/s | 110               | 130               | 165               | 195               | 260               |
| Volume flow at dryer inlet           | cfm | 233               | 275               | 350               | 413               | 551               |
| Pressure drop at maximum flow        | bar | 0.18              | 0.278             | 0.18              | 0.278             | 0.278             |
| Pressure drop at maximum flow        | psi | 2.61              | 4.03              | 2.61              | 4.03              | 4.03              |
| Time to half a cycle                 | s   | 87                | 87                | 87                | 87                | 87                |
| Regeneration time                    | s   | 65                | 65                | 65                | 65                | 65                |
| Pressurization time                  | s   | 20                | 20                | 20                | 20                | 20                |
| Average regeneration air consumption | %   | 16.5              | 16.5              | 16.5              | 17                | 17                |
| Desiccant type                       |     | Activated alumina | Activated alumina | Activated alumina | Activated alumina | Activated alumina |
| Desiccant amount per vessel          | kg  | 14.8              | 18.8              | 14.8              | 18.8              | 18.8              |
| Desiccant amount per vessel          | lb  | 32.6              | 41.4              | 32.6              | 41.4              | 41.4              |
| Inlet filter 1                       |     | UD 140+           | UD 140+           | UD 180+           | UD 220+           | UD 310+           |
| Outlet filter 1                      |     | DDp 130+          | DDp 130+          | DDp 170+          | DDp 210+          | DDp 310+          |
| Maximum air outlet temperature       | °C  | 60                | 60                | 60                | 60                | 60                |
| Maximum air outlet temperature       | °F  | 140               | 140               | 140               | 140               | 140               |
| Minimum volume flow at inlet         | l/s | 27.5              | 32.5              | 41.25             | 48.75             | 65                |
| Minimum volume flow at inlet         | cfm | 58.3              | 68.9              | 87.45             | 103.35            | 137.8             |

**High Efficiency (+) version, PDP -70 °C**

|                                      |     | <b>CD 25+</b>    | <b>CD 35+</b>    | <b>CD 45+</b>    | <b>CD 55+</b>    | <b>CD 65+</b>    | <b>CD 90+</b>    |
|--------------------------------------|-----|------------------|------------------|------------------|------------------|------------------|------------------|
| Volume flow at dryer inlet           | l/s | 25               | 35               | 45               | 55               | 65               | 90               |
| Volume flow at dryer inlet           | cfm | 53               | 74               | 95               | 116              | 138              | 191              |
| Pressure drop at maximum flow        | bar | 0.035            | 0.073            | 0.133            | 0.043            | 0.063            | 0.133            |
| Pressure drop at maximum flow        | psi | 0.51             | 1.06             | 1.93             | 0.62             | 0.91             | 1.93             |
| Time to half a cycle                 | s   | 87               | 87               | 87               | 87               | 87               | 87               |
| Regeneration time                    | s   | 65               | 65               | 65               | 65               | 65               | 65               |
| Pressurization time                  | s   | 20               | 20               | 20               | 20               | 20               | 20               |
| Average regeneration air consumption | %   | 24               | 24               | 24               | 24               | 24               | 24               |
| Desiccant type                       |     | Molecular sieves | Molecular sieves | Molecular sieves | Molecular sieves | Molecular sieves | Molecular sieves |
| Desiccant amount per vessel          | kg  | 10.9             | 13.0             | 16.5             | 10.9             | 13.0             | 16.5             |
| Desiccant amount per vessel          | lb  | 24.0             | 28.7             | 36.4             | 24.0             | 28.7             | 36.4             |
| Inlet filter 1                       |     | UD 25+           | UD 45+           | UD 45+           | UD 60+           | UD 140+          | UD 140+          |
| Outlet filter 1                      |     | DDp 35+          | DDp 50+          | DDp 50+          | DDp 70+          | DDp 130+         | DDp 130+         |
| Maximum air outlet temperature       | °C  | 60               | 60               | 60               | 60               | 60               | 60               |
| Maximum air outlet temperature       | °F  | 140              | 140              | 140              | 140              | 140              | 140              |
| Minimum volume flow at inlet         | l/s | 6.25             | 8.75             | 11.25            | 13.75            | 16.25            | 22.5             |
| Minimum volume flow at inlet         | cfm | 13.25            | 18.55            | 23.85            | 29.15            | 34.45            | 47.7             |

|                               |     | <b>CD 110+</b> | <b>CD 130+</b> | <b>CD 165+</b> | <b>CD 195+</b> |
|-------------------------------|-----|----------------|----------------|----------------|----------------|
| Volume flow at dryer inlet    | l/s | 110            | 130            | 165            | 195            |
| Volume flow at dryer inlet    | cfm | 233            | 275            | 350            | 413            |
| Pressure drop at maximum flow | bar | 0.08           | 0.123          | 0.112          | 0.156          |
| Pressure drop at maximum flow | psi | 1.16           | 1.78           | 1.62           | 2.26           |
| Time to half a cycle          | s   | 87             | 87             | 87             | 87             |
| Regeneration time             | s   | 65             | 65             | 65             | 65             |
| Pressurization time           | s   | 20             | 20             | 20             | 20             |

|                                      |     | <b>CD 110+</b>   | <b>CD 130+</b>   | <b>CD 165+</b>   | <b>CD 195+</b>   |
|--------------------------------------|-----|------------------|------------------|------------------|------------------|
| Average regeneration air consumption | %   | 24               | 25               | 25               | 26               |
| Desiccant type                       |     | Molecular sieves | Molecular sieves | Molecular sieves | Molecular sieves |
| Desiccant amount per vessel          | kg  | 13.0             | 16.5             | 16.5             | 16.5             |
| Desiccant amount per vessel          | lb  | 28.7             | 36.4             | 36.4             | 36.4             |
| Inlet filter 1                       |     | UD 140+          | UD 140+          | UD 180+          | UD 220+          |
| Outlet filter 1                      |     | DDp 130+         | DDp 130+         | DDp 170+         | DDp 210+         |
| Maximum air outlet temperature       | °C  | 60               | 60               | 60               | 60               |
| Maximum air outlet temperature       | °F  | 140              | 140              | 140              | 140              |
| Minimum volume flow at inlet         | l/s | 27.5             | 32.5             | 41.25            | 48.75            |
| Minimum volume flow at inlet         | cfm | 58.3             | 68.9             | 87.45            | 103.35           |

## 12 Instructions for use

### Instructions

|   | Description  |
|---|--|
| 1 | The dryers can contain pressurized air. This can be potentially dangerous if the equipment is misused.   |
| 2 | The towers of the dryer consist of an extruded profile, which must only be used as a vessel and must be operated within the limits specified. See section <a href="#">Pressure Equipment Directives</a> , table A.                                     |
| 3 | No alterations shall be made to the vessels by welding, drilling or other mechanical methods without the written permission of the manufacturer.   |
| 4 | The design pressure and temperature of this pressure bearing part must be clearly indicated on the data label.   |
| 5 | If installed, the safety valve must correspond with pressure surges of 1.1 times the maximum allowable operating pressure. This should guarantee that the pressure will not permanently exceed the maximum allowable operating pressure of the vessel. |
| 6 | Original bolts have to be used after opening for inspection. The maximum torque has to be taken into consideration (see table below).  |

### Maximum bolt torque

| Thread size | Tightening torque (Nm) | Allowed deviation (Nm) |
|-------------|------------------------|------------------------|
| M3          | 1                      | 0.3                    |
| M4          | 2.4                    | 0.6                    |
| M5          | 5                      | 1.2                    |
| M6          | 8                      | 2.1                    |
| M8          | 20                     | 5                      |
| M10         | 41                     | 10                     |
| M12         | 73                     | 18                     |
| M14         | 115                    | 29                     |
| M16         | 185                    | 46                     |
| M18         | 238                    | 60                     |
| M20         | 335                    | 84                     |

## 13 Guidelines for inspection

### Guidelines

On the Declaration of Conformity / Declaration by the Manufacturer, the harmonized and/or other standards that have been used for the design are shown and/or referred to.

The Declaration of Conformity / Declaration by the Manufacturer is part of the documentation that is supplied with this air dryer.

Local legal requirements and/or use outside the limits and/or conditions as specified by Atlas Copco may require other inspection periods as mentioned below.

## 14 Pressure Equipment Directives

### Components Subject to Pressure Equipment Directive (PED) 2014/68/EU

Parts of article 4.3 of 2014/68/EU are subject to Sound Engineering Practice (SEP).

Parts of category I according to 2014/68/EU are integrated into the machine and fall under the exclusion of article I, section 2-(f)-(i).

The table below contains the necessary information for the inspection of all category I pressure equipment according to Pressure Equipment Directive (PED) 2014/68/EU.

| Tube drawing p.n. | Design pressure bar(e) | Design temperature °C | PED category | Tube wall thickness mm | Tube diameter mm | Tube internal volume l |
|-------------------|------------------------|-----------------------|--------------|------------------------|------------------|------------------------|
| 1627 6307 91      | 14                     | -10 to +66            | I            | 5                      | 150              | 9.8                    |
| 1627 6307 92      | 14                     | -10 to +66            | I            | 5                      | 150              | 10.5                   |
| 1627 6307 93      | 14                     | -10 to +66            | I            | 5                      | 150              | 13.6                   |
| 1627 6307 94      | 14                     | -10 to +66            | I            | 5                      | 150              | 16.8                   |
| 1627 6307 95      | 14                     | -10 to +66            | I            | 5                      | 150              | 19.5                   |
| 1627 6307 96      | 14                     | -10 to +66            | I            | 5                      | 150              | 24.7                   |

### Recommendation of the manufacturer for inspection intervals

Following actions are to be executed by authorized service personnel only, unless stated otherwise in the applicable legislation. The stated time interval takes the start-up day of the unit as reference.

- Every 6 months: inspect the vessel material on the outside (exposed) for traces of strong corrosion. Consult the service department of your supplier if necessary.
- Every 5 years: when replacing the desiccant, following inspections are to be carried out:
  - Inspection of outside and inside of the material for excessive and local corrosion.
  - Inspection of outside and inside of the material for fissures, leaks, and damage.
 Consult the service department of your supplier if necessary.
- Hydrostatic test according to the Pressure Equipment Directive (PED) 2014/68/EU when required by local regulations. Consult the service department of your supplier if necessary.

# 15 Declaration of conformity

Insert logo here

## EU DECLARATION OF CONFORMITY

- 1
- 2 We, (1) declare under our sole responsibility, that the product
- 3 Machine name :
- 4 Machine type :
- 5 Serial number :
- 6 Which falls under the provisions of article 12.2 of the EC Directive 2006/42/EC on the approximation of the laws of the Member States relating to machinery, is in conformity with the relevant Essential Health and Safety Requirements of this directive.

The machinery complies also with the requirements of the following directives and their amendments as indicated.

7

|   | Directive on the approximation of laws of the Member States relating to | Harmonized and/or Technical Standards used | Att'mnt |
|---|---|--|---------|
| a | (2)   | (3)  |         |
| b |   |  | X       |
| c |   |  |         |
| d |   |  | X       |
| e |   |  |         |
| f |   |  |         |
| g |   |  | X       |

- 8a The harmonized and the technical standards used are identified in the attachments hereafter
- 8b <1> is authorized to compile the technical file.
- |              |  |  |
|--------------|--|--|
|              | <b>Conformity of the specification to the directives</b> | <b>Conformity of the product to the specification and by implication to the directives</b> |
| 11 Issued by | Engineering  | Manufacturing  |
| 12           |  |  |
| 13 Name      |  |  |
| 14 Signature |  |  |
| 15 Date      |  |  |
| 16 Place     |  |  |

84950D

*Typical example of a Declaration of Conformity document*

(1): Contact address:

Atlas Copco Airpower n.v.  
 P.O. Box 100  
 B-2610 Wilrijk (Antwerp)  
 Belgium

(2): Applicable directives

(3): Standards used

On the Declaration of Conformity / Declaration by the Manufacturer, the harmonized and/or other standards that have been used for the design are shown and/or referred to.

The Declaration of Conformity / Declaration by the Manufacturer is part of the documentation that is supplied with this device.



## ***COMMITTED TO SUSTAINABLE PRODUCTIVITY***

We stand by our responsibilities towards our customers, towards the environment and the people around us. We make performance stand the test of time. This is what we call — Sustainable Productivity.

[www.atlascopco.com](http://www.atlascopco.com)

